

Product Data Sheet

PS-00566, Rev. D

March 2007

Micro Motion® LF-Series Low Flow Sensor and Transmitter

with MVD™ technology



Micro Motion® LF-Series flowmeters

Micro Motion® LF-Series meters are the smallest Coriolis meters available on the market. With a footprint the size of a handheld organizer, you can fit this meter into any tight space for your low-flow needs.

Not only is the footprint small – so are the flow rates. With a range of 0.022 to 59.5 lb/hr (0.001 to 27 kg/h), you can measure mass or volume flow for drops of liquid, slurries, or gas.

Like other Micro Motion meters, the LF-Series offers all the benefits of Coriolis:

- High accuracy, for a quicker ROI
- No moving parts, for reduced maintenance costs and downtime
- Direct measurement of mass, volume, temperature, and density for reduced instrumentation requirements
- Measurements unaffected by changing fluid properties, for no special installation requirements or manual calculations

Applications

Whatever your low-flow application – flavoring, fragrances, or catalysts; whatever your industry – chemical, life sciences, food and beverage, oil and gas; Micro Motion's LF-Series flowmeter can measure it. And install it wherever you want: pilot plant, research, or processing.

LF-Series transmitters with MVD™

LF-Series transmitters are specially designed to work with LF-Series sensors on your low-flow applications. LF-Series transmitters incorporate MVD technology – an innovative, multivariable, digital signal processing capability.

MVD technology:

- Improves ease of use with an easy-to-use display
- Reduces downtime with enhanced diagnostics
- Lowers your flowmetering costs with a 4-wire connection.

Transmitter features include:

- Milliampere and frequency/pulse outputs
- Transmitter and process control functions in a single device
- Field-mount or DIN rail mount transmitter
- Optional NEMA enclosures (field-mount transmitters only)

Make your process more profitable

Micro Motion LF-Series sensors and transmitters can be installed as part of a HART® Bell 202 multidrop network, a Modbus® RS-485 digital communications network, or a PROFIBUS-PA or FOUNDATION fieldbus™ system.

All transmitters support Emerson Process Management's PlantWeb® field-based architecture, which uses the power of intelligent, interoperable field devices to improve plant performance.

Micro Motion is known worldwide for increasing plant efficiency, production, and profitability. More than 500,000 Micro Motion meters are installed and working in processes just like yours.



Sensor specifications

Liquid flow rates

		Mass		Volume ⁽¹⁾	
		lb/hr	kg/h	gal/hr	l/h
Maximum flow range	LF2M	0.84	0.38	0.10	0.38
	LF3M	2.21	1.00	0.26	1.00
	LF4M	69.54	27.00	7.13	27.00

(1) Volume measurement is based on a process-fluid density of 1 g/cm³ (1000 kg/m³). For fluids with density other than 1 g/cm³, the volumetric flow rate equals the maximum mass flow rate divided by the fluid's density.

Gas flow rates

Flow rates that produce approximately 14.5 psid (1.0 bar) pressure drop on air at 70 °F (21.1 °C) and 500 psi (35 bar)

		Mass		Volume	
		lb/hr	kg/h	SCFH	SCCM
Typical flow range	LF2M	0.227	0.103	3.034	1432
	LF3M	0.893	0.405	11.86	5595
	LF4M	8.026	3.640	106.7	50,350

Liquid and gas performance

Mass flow accuracy⁽¹⁾	Standard	$\pm 1.0\%$ of rate or $\pm \left[\left(\frac{\text{zero stability}}{\text{flow rate}} \right) \times 100 \right]$ % of rate, whichever is greater
	Optional	$\pm 0.5\%$ of rate or $\pm \left[\left(\frac{\text{zero stability}}{\text{flow rate}} \right) \times 100 \right]$ % of rate, whichever is greater

Mass flow repeatability	$\pm 0.05\%$ of rate or $\pm \frac{1}{2} \left[\left(\frac{\text{zero stability}}{\text{flow rate}} \right) \times 100 \right]$ % of rate, whichever is greater
--------------------------------	---

(1) Stated flow accuracy includes the combined effects of repeatability, linearity, and hysteresis. All specifications for liquids are based on reference conditions of water at 70 °F (21.1 °C).

Sensor specifications *continued*

Liquid and gas performance *continued*

Mass flow reproducibility		$\pm 0.05\%$ of rate or $\pm \frac{1}{2} \left[\left(\frac{\text{zero stability}}{\text{flow rate}} \right) \times 100 \right]$ % of rate, whichever is greater	
Zero stability		lb/hr	kg/h
	LF2M	0.0003	0.00013
	LF3M	0.0022	0.00100
	LF4M	0.0088	0.00400
Density	Range ⁽¹⁾	0 to 0.3 g/cm ³ (gas) and 0.5 to 2.0 g/cm ³ (liquid)	
	Accuracy ⁽²⁾ —liquid only	± 0.005 g/cm ³	
	Repeatability—liquid only	± 0.002 g/cm ³	
Temperature	Ambient and process	0 to 65 °C (32 to 149 °F)	
	Accuracy	± 0.5 °C (± 1.0 °F)	
Maximum operating pressure	Standard	35 bar (500 psi)	
	Optional	100 bar (1500 psi)	

(1) Contact factory for applications with fluid density between 0.3 and 0.5 g/cm³.

(2) At temperatures other than 70 °F (21.1 °C), you can expect an additional density error of approximately 0.0005 g/cm³ per °C.

Hazardous area classifications

CSA⁽¹⁾	Class I Division 2 Groups A, B, C, D Class II Division 2 Groups F and G Class III Division 2
ATEX⁽²⁾	 II 3 G EEx nA II T4 II 3 D IP65 T135°C

(1) CSA is a Canadian approvals agency that provides approvals accepted both in the U.S.A. and in Canada.

(2) ATEX is a European directive.

Sensor specifications *continued*

Materials of construction

Wetted parts	316/316L stainless steel
Optional filter components (wetted)	302 and 316 stainless steel
Process seals	Viton [®] fluoroelastomer ⁽¹⁾ , Buna, Kalrez, or EPDM
Housing	Epoxy-painted aluminum

(1) Viton is a registered trademark of DuPont Performance Elastomers.

Physical specifications

Weight	4 lbs (2 kg)
Shipping weight	5 lbs (2 kg)

Dimensions

Model	Fitting options	Fitting code	Dim. A with filter inches (mm)	Dim. A without filter inches (mm)	Dim. B inches (mm)
All	1/4" tube compression fittings	324	6 1/4 (158)	5 (126)	2 1/2 (63)
	1/8" tube compression fittings	328	5 15/16 (151)	4 11/16 (119)	2 5/16 (59)
	1/8" VCR	327	5 11/16 (144)	4 3/8 (112)	2 3/16 (56)
	1/4" VCR	322	6 3/8 (162)	5 1/8 (129)	2 9/16 (65)
	1/4" VCO	323	5 7/8 (149)	4 5/8 (117)	2 5/16 (59)
	6 mm tube compression fittings	325	6 1/4 (158)	5 (126)	2 1/2 (63)

Sensor specifications *continued*

Dimensions *continued*

Dimensions in inches (mm)

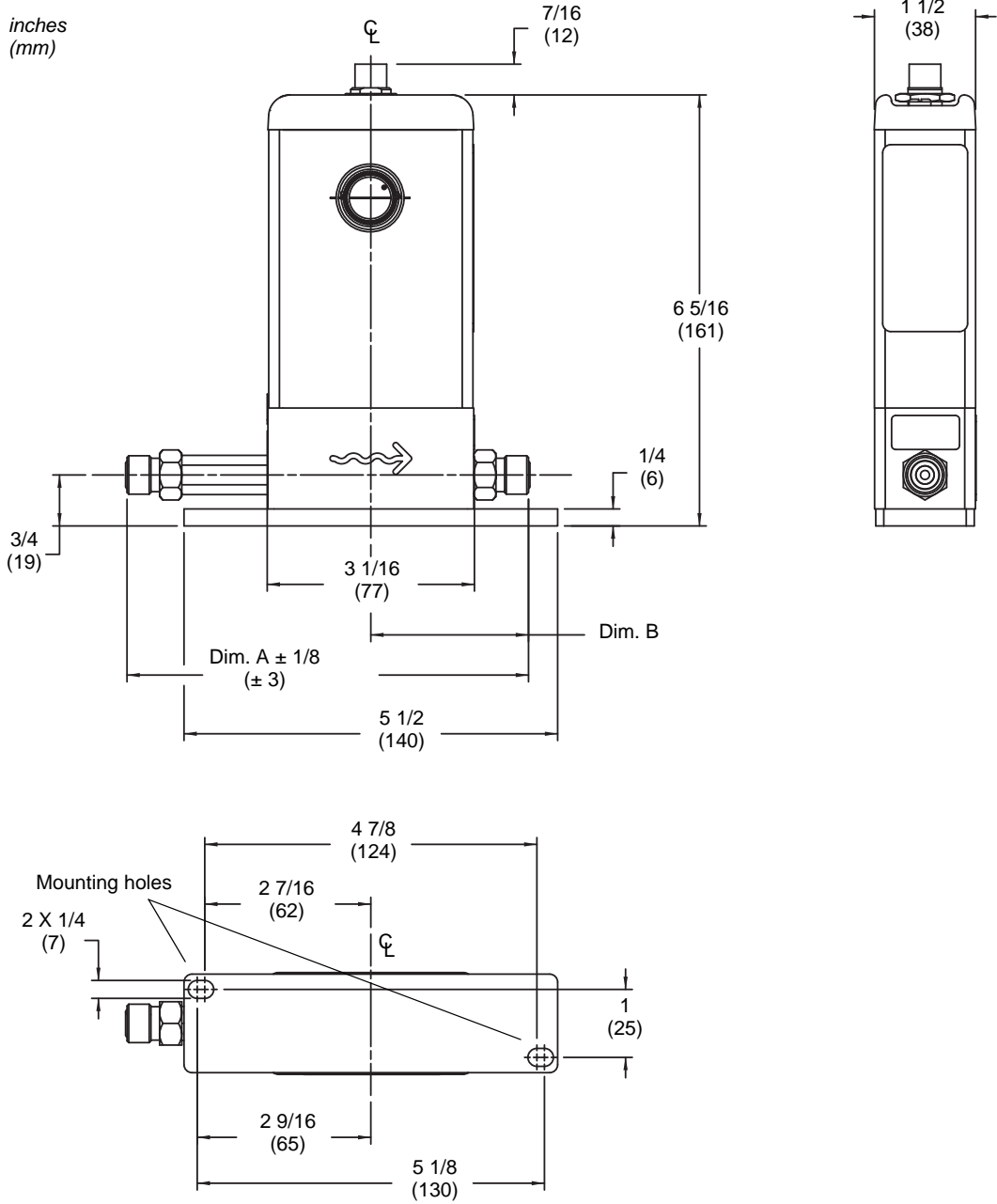

Transmitter specifications

Transmitter outputs

	Field mount	DIN rail mount
1 mA output, 1 frequency/pulse output	Mounting and outputs codes 1 and 3 (FM AN)	Mounting and outputs code 2 (DIN AN)
2 mA outputs, 1 frequency/pulse output (configurable)	Mounting and outputs code 4 (FM CIO)	Mounting and outputs code 5 (DIN CIO)
FOUNDATION fieldbus	Mounting and outputs code 6 (FM FB)	(Not available)
PROFIBUS-PA	Mounting and outputs code 7 (FM PB)	(Not available)

Transmitters with configurable I/O

The field-mount and DIN rail transmitters (mounting and outputs codes 4 and 5, with configurable I/O), are designed to increase transmitter flexibility and reduce the number of transmitter variations required in inventory.

The table below shows the various configuration options that can be produced with the configurable I/O output option. All transmitters ship with the default, but can be configured in the field.

Channel	Terminals		Configuration option	Default process variable assignment	Power
	Field mount	DIN rail			
A	1 & 2	21 & 22	mA output 1 (with Bell 202 HART)	Mass flow	Internal (active)
B	3 & 4	23 & 24	mA output 2 (default)	Density	Internal (active)
			Frequency output (FO) ⁽¹⁾	Mass flow	Internal (active) or external (passive)
			Discrete output 1 (DO1)	Fwd/Rev	
C	5 & 6	31 & 32	Frequency output (FO) (default) ⁽¹⁾	Mass flow	Internal (active) or external (passive)
			Discrete output 2 (DO2)	Flow switch	
			Discrete input (DI)	None	

(1) When configured for two FOs (dual pulse), FO2 is generated from the same FO signal sent to the first FO. FO2 is electrically isolated but not independent.

Transmitter specifications *continued*

Transmitters with FOUNDATION fieldbus

FOUNDATION fieldbus software is designed to permit remote testing and configuration of the transmitter using DeltaV Fieldbus Configuration Tool, or other FOUNDATION fieldbus compliant hosts. The Coriolis sensor signal is channeled through the flowmeter to the control room and the FOUNDATION fieldbus configuration device.

- The transducer block holds the data from the Coriolis sensor. It includes information about the sensor type, sensor configuration, engineering units, calibration, damping, and diagnostics.
- The resource block contains physical device information, including available memory, manufacturer identification, type of device, and features.
- The Analog Input (AI) function block processes the measurement from the Coriolis sensor and makes it available to other function blocks. It also allows filtering, alarm handling, and engineering unit changes. Each of the four LF-Series Transmitter function blocks can be assigned to one variable from the five available: mass flow, volume flow, density, temperature, and drive gain.
- The Analog Output (AO) function block assigns an output value to a field device through a specified channel. The block supports mode control, signal status calculation, and simulation.
- The proportional integral derivative (PID) function block combines all the necessary logic to perform proportional/integral/derivative control. The block supports mode control, signal scaling and limiting, feed forward control, override tracking, alarm limit detection, and signal status propagation.
- The integrator block provides functionality for the transmitter totalizers. The flow variable (mass or volume) can be selected and reset.

Transmitter diagnostics and service

LF-Series transmitters automatically perform continuous self-diagnostics. Using the transducer block, the user can perform on-line testing of the transmitter and sensor. Diagnostics are event-driven and do not require polling for access.

The new meter fingerprinting feature allows you to capture device-level snapshots of your meter performance.

Transmitter specifications *continued*

Field mount

Physical specifications	Housing	Polyurethane-painted cast aluminum, NEMA 4X (IP 67)
	Weight	With display: 3.6 kg (8 lb) Without display: 3.2 kg (7 lb)
	Mounting and cabling	Transmitters include a mounting bracket. Hardware for installing the transmitter on the mounting bracket is included. The transmitter can be rotated on the mounting bracket 360° in 90° increments. Cable with a pre-installed Eurofast connector can be purchased in lengths up to 1000 ft (300 m).
	Interface/display (optional)	Segmented 2-line LCD display with optical controls and flowmeter-status LED is standard. <ul style="list-style-type: none">• LCD line 1 lists the process variable.• LCD line 2 lists engineering unit of measure. Non-glare tempered glass lens. Available in both backlit and non-backlit versions. Display is suitable for hazardous area installation. To facilitate various mounting orientations, the display can be rotated on the transmitter 360° in 90° increments. Display controls feature optical switches that are operated through the glass with a red LED for visual feedback to confirm when a “button” is pressed. Display functions: <ul style="list-style-type: none">• View process variables• Start, stop, and reset totalizers• View and acknowledge alarms• Off-line (where applicable):<ul style="list-style-type: none">- Zero flowmeter- Simulate outputs- Change measurement units- Configure outputs- Set RS-485 communications options
	Status light	Three-color LED status light on display panel indicates flowmeter condition at a glance.

Transmitter specifications *continued*

Field mount *continued*

Electrical connections	Input and output connections	One (mounting and outputs codes 6 and 7), two (mounting and outputs codes 1 and 3), or three (mounting and outputs code 4) pairs of wiring terminals for transmitter outputs Screw terminals accept one or two solid conductors, 14 to 12 AWG (2.5 to 4.0 mm ²); or one or two stranded conductors, 22 to 14 AWG (0.34 to 2.5 mm ²)
	Power connections	One pair of wiring terminals accepts AC or DC power One internal ground lug for power-supply ground wiring Screw terminals accept one or two solid conductors, 14 to 12 AWG (2.5 to 4.0 mm ²); or one or two stranded conductors, 22 to 14 AWG (0.34 to 2.5 mm ²)
	Service port connection	Two clips for temporary connection to the service port
	Sensor connection	Two pairs of terminals for the 4-wire connection to the sensor <ul style="list-style-type: none">• One pair is used for the RS-485 connection to the sensor• One pair is used to supply power to the sensor Plug connectors accept stranded or solid conductors, 24 to 12 AWG (0.2 to 2.5 mm ²)

Input/output signals	All transmitters	One 4-wire sensor signal input connection with ground
	Mounting and outputs code 1 or 3 (1 mA, 1 FO)	One active 4–20mA output <ul style="list-style-type: none">• Not intrinsically safe• Isolated to ± 50 VDC from all other outputs and earth ground• Maximum load limit: 820 ohms• Flow-only transmitter can report mass flow or volume flow• Multivariable transmitter can report mass flow, volume flow, density, temperature, or drive gain• Output is linear with process from 3.8 to 20.5 mA, per NAMUR NE43 (June 1994)

Transmitter specifications *continued*

Field mount *continued*

Mounting and outputs code 4
(2 mA, 1 FO configurable,
multivariable transmitter only)

- One active or passive frequency/pulse output
- Not intrinsically safe
- Can report mass flow or volume flow, which can be used to indicate flow rate or total
- Flow-only transmitter: frequency output reports the same flow variable as the mA output
- Multivariable transmitter: frequency output is independent of the mA output
- Scalable to 10,000 Hz
- Maximum output of +24 VDC $\pm 3\%$ with a 2.2 kohm internal pull-up resistor
- Output is linear with flow rate to 12,500 Hz

- One or two active 4–20 mA outputs
- Not intrinsically safe
- Isolated to ± 50 VDC from all other outputs and earth ground
- Maximum load limit:
 - mA1: 820 ohms
 - mA2: 420 ohms
- Can report mass flow, volume flow, density, temperature, or drive gain
- Output is linear with process from 3.8 to 20.5 mA, per NAMUR NE43 (June 1994)

- One active or passive frequency/pulse output
- Not intrinsically safe
- Can report mass flow or volume flow, which can be used to indicate flow rate or total
- Scalable to 10,000 Hz
- Power:
 - Internal (active): +15 VDC $\pm 3\%$ with a 2.2 kohm internal pull-up resistor
 - External (passive): +30 VDC maximum, +24 VDC typical, sinking up to 500 mA at 30 VDC.
- Output is linear with flow rate to 12,500 Hz

- One or two active or passive discrete outputs
 - Not intrinsically safe
 - Can report five discrete events: flow switch, forward/reverse flow, calibration in progress, or fault
 - Power:
 - Internal (active): +15 VDC $\pm 3\%$ with a 2.2 kohm internal pull-up resistor
 - External (passive): +30 VDC maximum, +24 VDC typical, sinking up to 500 mA at 30 VDC
-

Transmitter specifications *continued*

Field mount *continued*

		<p>One discrete input</p> <ul style="list-style-type: none">• Can be configured for internal or external power• Not intrinsically safe• Power<ul style="list-style-type: none">- Internal (active): +15 VDC, 7 mA maximum source current- External (passive): +3 to 30 VDC maximum• Can start/stop totals and inventories, reset all totals, reset mass total, reset volume total, start sensor zero, or initiate multiple actions
	Mounting and outputs code 6 (FOUNDATION fieldbus)	<p>One FOUNDATION fieldbus H1 output</p> <p>Manchester-encoded digital signal conforms to IEC 1158-2. Intrinsically safe with an intrinsically safe power supply.</p> <p>Transmitter fieldbus circuit is passive, and draws power from the fieldbus segment. Current draw from the fieldbus segment is 11.5 mA.</p>
	Mounting and outputs code 7 (PROFIBUS-PA)	<p>One PROFIBUS-PA output</p> <p>Manchester-encoded digital signal conforms to IEC 1158-2. Intrinsically safe with an intrinsically safe power supply.</p>
Digital communications	All transmitters	<p>One service port can be used for temporary connection only</p> <p>Uses RS-485 Modbus signal, 38.4 kilobaud, one stop bit, no parity</p>
	Mounting and outputs code 1, 3, or 4	<p>HART Bell 202 signal is superimposed on the primary milliamp output, and is available for host system interface:</p> <ul style="list-style-type: none">• Frequency: 1.2 and 2.2 kHz• Amplitude: to 1.0 mA• 1200 baud• Requires 250 to 600 ohms resistance
	Mounting and outputs code 1 or 3	<p>One RS-485 output can be used for direct connection to a HART or Modbus host system. Modbus communications supports 7-bit or 8-bit protocol (default: 8-bit), 1200 to 38,400 baud (default: 9600), one or two stop bits (default: one), and odd, even, or no parity (default: odd). Configuration can be changed using Micro Motion® ProLink® II software.</p>









Transmitter specifications *continued*

Field mount *continued*

Mounting and outputs code 6 (FOUNDATION fieldbus)	<p>Transmitters are registered with the Fieldbus Foundation, and conform to the FOUNDATION fieldbus H1 protocol specification.</p> <p>FISCO: Field device in compliance with TS-60079-27:2002</p> <ul style="list-style-type: none"> • $U_i = 30\text{ V}$, $I_i = 380\text{ mA}$, $P_i = 5.32\text{ W}$, $C_i = \text{negligible}$, $L_i = \text{negligible}$ •
Mounting and outputs code 7 (PROFIBUS-PA)	<p>Transmitters are registered with the Profibus Organization, and fulfill the requirements of the PROFIBUS-PA Profile for Process Control Devices.</p> <p>FISCO: Field device in compliance with TS-60079-27:2002</p> <ul style="list-style-type: none"> • $U_i = 30\text{ V}$, $I_i = 380\text{ mA}$, $P_i = 5.32\text{ W}$, $C_i = \text{negligible}$, $L_i = \text{negligible}$ <p>Siemens® Simatic® PDM required for configuration.</p>
Power supply	<p>Self-switching AC/DC input, automatically recognizes supply voltage.</p> <p>Complies with low voltage directive 73/23/EEC per IEC 1010-1 with amendment 2.</p> <p>Installation (Overvoltage) Category II, Pollution Degree 2.</p> <p>The transmitter fieldbus circuit is passive, and draws its power from the fieldbus segment.</p> <p>Current draw from the fieldbus segment is 11.5 mA.</p>
AC power	85 to 265 VAC, 50/60 Hz, 6 watts typical, 11 watts maximum
DC power	<p>18 to 100 VDC, 6 watts typical, 11 watts maximum</p> <p>At startup, transmitter power source must provide a minimum of 1.5 amperes of short-term current at a minimum of 18 volts at the transmitter's power input terminals.</p> <p>Minimum 22 VDC with 1000 feet of 18 AWG (300 meters of 0.8 mm²) power supply cable</p>
Fuse	IEC 127-1.25 fuse, slow blow
Environmental limits	<p>Ambient temperature limits</p> <p>Operating and storage: -40 to $+140\text{ °F}$ (-40 to $+60\text{ °C}$)</p> <p>Display responsiveness decreases and display may become difficult to read below -4 °F (-20 °C). Above 131 °F (55 °C), some darkening of the display might occur.</p> <p>ATEX requires limiting ambient temperature to below 131 °F (55 °C).</p> <p>Humidity limits</p> <p>5 to 95% relative humidity, non-condensing at 140 °F (60 °C)</p>

Transmitter specifications *continued*

Field mount *continued*

	Vibration limits	Meets IEC68.2.6, endurance sweep, 5 to 2000 Hz, 50 sweep cycles at 1.0g.
Environmental effects	EMI effects	Complies with NAMUR NE21 (August 1998 German and May 1999 English). Meets EMC directive 89/336/EEC per EN 50081-2 (August 1993) and EN50082-2 (March 1995) and EN 61326 Industrial.
	Ambient temperature effect	On analog outputs $\pm 0.005\%$ of span per °C
Hazardous area classifications	CSA ⁽¹⁾	Class I Division 2 Groups A, B, C, D Class II Division 2 Groups F and G Class III Division 2
	ATEX ⁽²⁾	Output option codes 1, 3, or 4: With display:   II 3 G EEx nC IIB+H2 T6 II 3 D IP66/IP67 T65°C Without display or with optional display cover:   II 3 G EEx nC IIC T6 II 3 D IP66/IP67 T65°C Output option codes 6 and 7: With display:   II 3 G EEx nC [L] IIB+H2 T6 II 3 D IP66/IP67 T65°C Without display or with optional display cover:   II 3 G EEx nC [L] IIC T6 II 3 D IP66/IP67 T65°C

(1) CSA is a Canadian approvals agency that provides approvals accepted both in the U.S.A. and in Canada.

(2) ATEX is a European directive.

Transmitter specifications *continued*

Field mount *continued*

Dimensions

With display

Dimensions in inches
(mm)

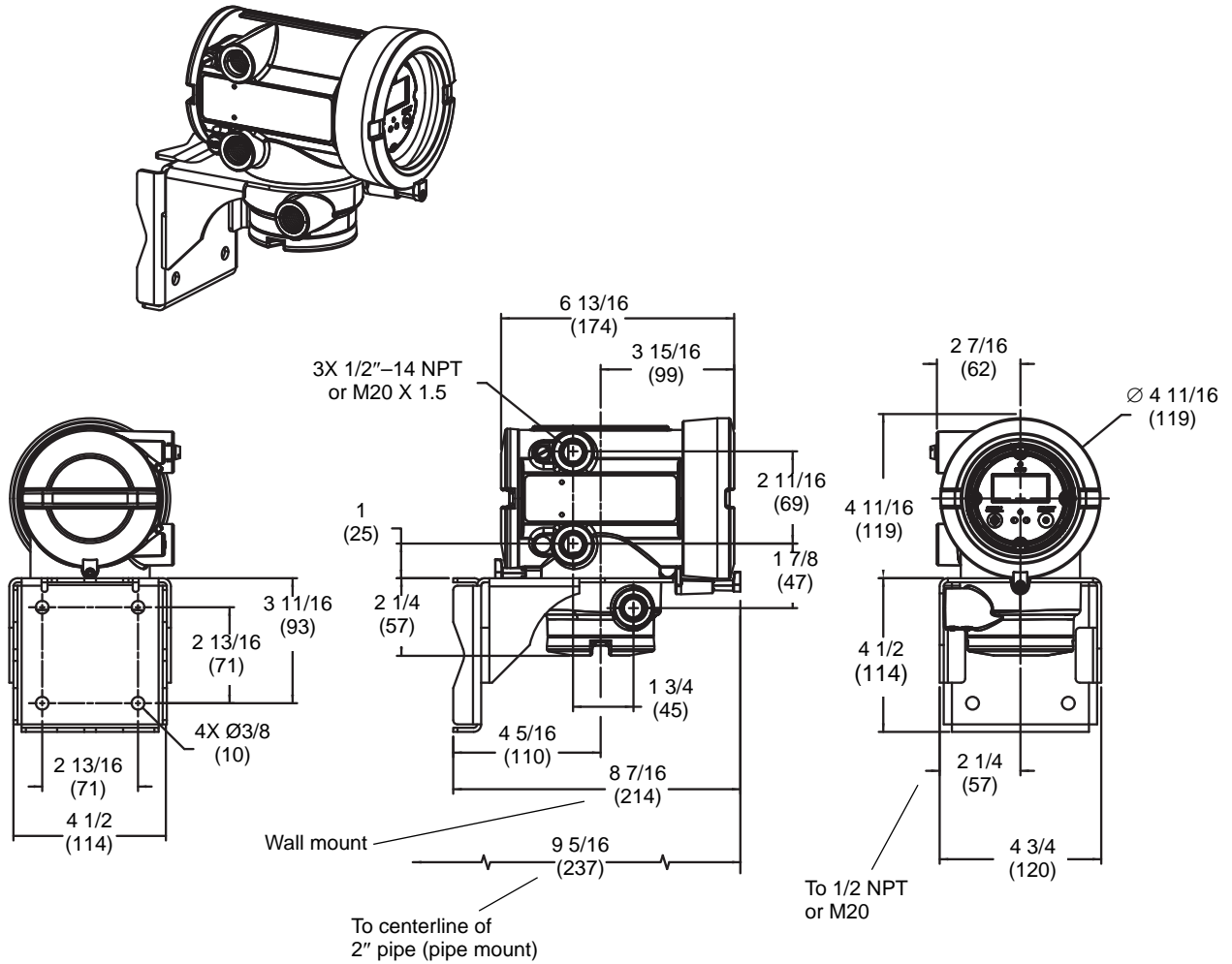

Transmitter specifications *continued*

Field mount *continued*

Without display

Dimensions in inches
(mm)

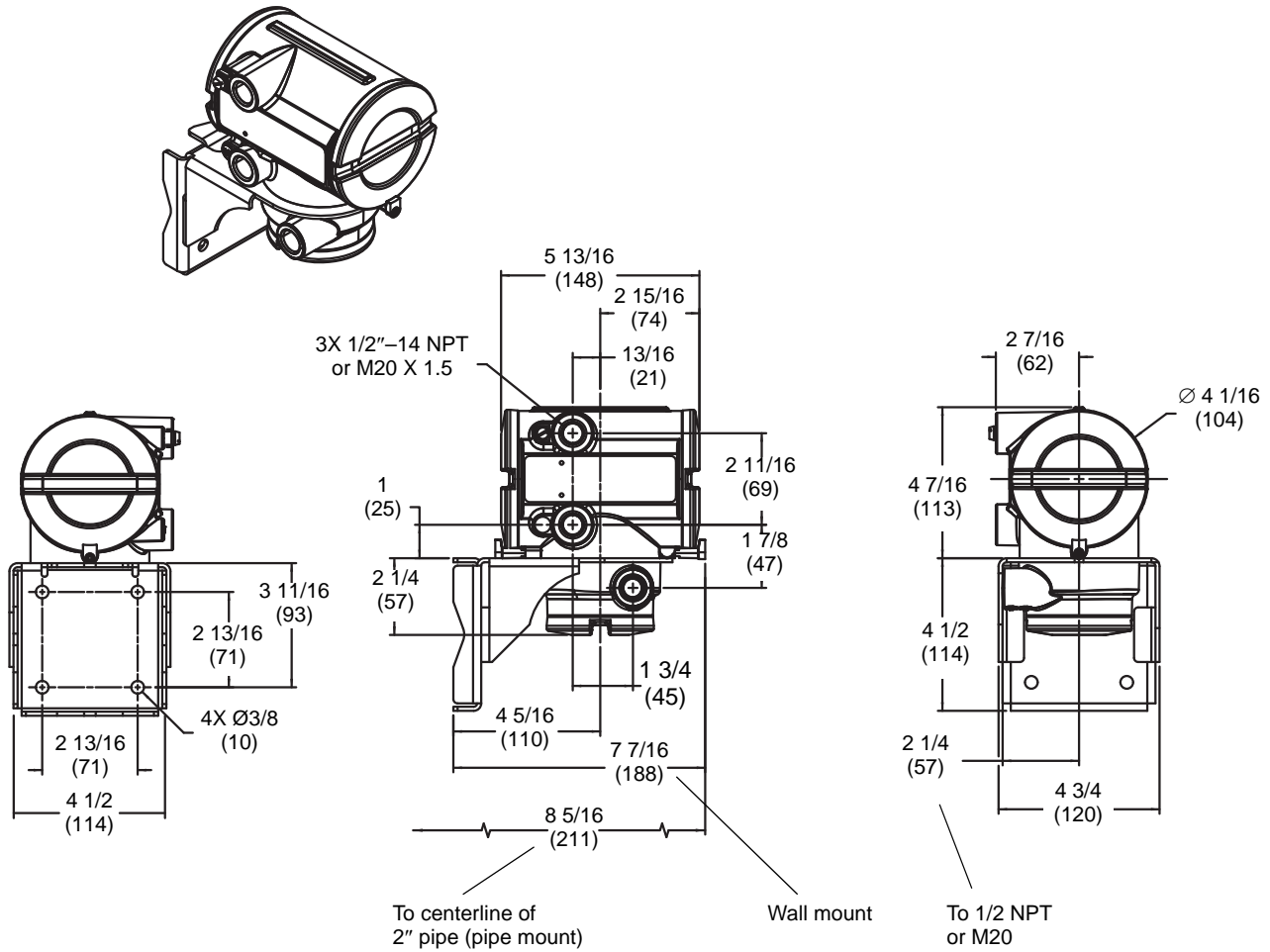

Transmitter specifications *continued*

DIN rail mount

Physical specifications	Housing	Polyamide PA 6.6
	Weight	0.52 lbs (0.24 kg)
	Mounting and cabling	DIN rail transmitters are mounted on a 35 mm rail. The rail must be grounded. Cable with a pre-installed Eurofast connector can be purchased in lengths up to 1000 ft (300 m).
	Status LED	Three-color LED status light on face of transmitter indicates flowmeter condition at a glance, using a solid green, yellow or red light. Zero in progress is indicated by a flashing yellow light.
	Zero button	A zero button on the face of the transmitter can be used to start the transmitter zero process.

Electrical connections	Input and output connections	Three pairs of wiring terminals for transmitter outputs One pair of terminals for digital communications (Modbus/RS-485) Plug connectors accept stranded or solid conductors, 24 to 12 AWG (0.2 to 3.5 mm ²)
	Power connections	Two pairs of terminals <ul style="list-style-type: none">• Either pair accepts DC power• The remaining pair is used for making a jumper connection to a second transmitter Plug connectors accept stranded or solid conductors, 24 to 12 AWG (0.2 to 3.5 mm ²)
	Sensor connection	The transmitter has two pairs for the 4-wire connection to the sensor <ul style="list-style-type: none">• One pair is used for the RS-485 connection to the sensor• One pair is used to supply power to the sensor Plug connectors accept stranded or solid conductors, 24 to 12 AWG (0.2 to 3.5 mm ²)

Input/output signals	All transmitters	One 4-wire sensor signal input connection with ground
-----------------------------	------------------	---

Transmitter specifications *continued*

DIN rail mount *continued*

Mounting and outputs code 2
(1 mA, 1 FO)

- One active 4–20mA output
- Not intrinsically safe
- Isolated to ± 50 VDC from all other outputs and earth ground
- Maximum load limit: 820 ohms
- Can report mass flow or volume flow
- Output is linear with process from 3.8 to 20.5 mA, per NAMUR NE43 (June 1994)

- One active or passive frequency/pulse output
- Not intrinsically safe
- Can report mass flow or volume flow, which can be used to indicate flow rate or total
- Frequency output reports the same flow variable as the mA output
- Scalable to 10,000 Hz
- Maximum output of +15 VDC $\pm 3\%$ with 2.2 kohm internal pull-up resistor
- Output is linear with flow rate to 12,500 Hz

Mounting and outputs code 5
(2 mA, 1 FO configurable,
multivariable transmitter only)

- One or two active 4–20 mA outputs
- Not intrinsically safe
- Isolated to ± 50 VDC from all other outputs and earth ground
- Maximum load limit:
 - mA1: 820 ohms
 - mA2: 420 ohms
- Can report mass flow, volume flow, density, temperature, or drive gain
- Output is linear with process from 3.8 to 20.5 mA, per NAMUR NE43 (June 1994)

- One active or passive frequency/pulse output
 - Not intrinsically safe
 - Can report mass flow or volume flow, which can be used to indicate flow rate or total
 - Scalable to 10,000 Hz
 - Power:
 - Internal (active): +15 VDC $\pm 3\%$ with 2.2 kohm internal pull-up resistor
 - External (passive): +30 VDC maximum, 24 VDC typical, sinking up to 500 mA at 30 VDC
 - Output is linear with flow rate to 12,500 Hz
-

Transmitter specifications *continued*

DIN rail mount *continued*

		<p>One or two active or passive discrete outputs</p> <ul style="list-style-type: none">• Not intrinsically safe• Can report five discrete events: flow switch, forward/reverse flow, calibration in progress, or fault• Power:<ul style="list-style-type: none">- Internal (active): +15 VDC \pm3% with 2.2 kohm internal pull-up resistor- External (passive): +30 VDC maximum, +24 VDC typical, sinking up to 500 mA at 30 VDC• Maximum sink capability: 500 mA <p>One discrete input</p> <ul style="list-style-type: none">• Can be configured for internal or external power• Not intrinsically safe• Power:<ul style="list-style-type: none">- Internal: +15 VDC, 7 mA maximum source current- External: +3 to 30 VDC maximum• Can start/stop totals and inventories, reset all totals, reset mass total, reset volume total, start sensor zero, or initiate multiple actions
Digital communications	All transmitters	<p>One pair of terminals supports Modbus/RS485 signal or SP (service port) mode. HART/Bell 202 signal is superimposed on the primary mA output, and is available for host system interface</p> <ul style="list-style-type: none">• Frequency: 1.2 and 2.2 kHz• Amplitude: to 1.0 mA• 1200 baud• Requires 250 to 600 ohms load resistance
Power supply	<p>Transmitter's power supply:</p> <ul style="list-style-type: none">• Requires DC power• Meets Installation (Overvoltage) Category II, Pollution Degree 2 requirements• Contains an IEC 1.6A slow blow fuse <p>Power requirements</p>	<p>Minimum 19.2 to 28.8 VDC, 6.3 watts</p> <p>At startup, transmitter power source must provide a minimum of 1.0 amperes of short-term current per transmitter</p> <p>Length and conductor diameter of the power cable must be sized to provide 19.2 VDC minimum at the power terminals, at a load current of 330 mA</p>

Transmitter specifications *continued*

DIN rail mount *continued*

Environmental limits	Ambient temperature limits	Operating: -40 to +131 °F (-40 to +55 °C) Storage: -40 to +185 °F (-40 to +85 °C) If temperature is above 113 °F (45 °C) and you are mounting multiple transmitters, they must be mounted at least 8.5 mm apart.
	Humidity limits	5 to 95% relative humidity, non-condensing at 140 °F (60 °C)
	Vibration limits	Meets IEC68.2.6, endurance sweep, 5 to 2000 Hz, 50 sweep cycles at 1.0g.

Environmental effects	EMI effects	Complies with NAMUR NE21 (August 1998 German and May 1999 English). Meets EMC directive 89/336/EEC per EN 50081-2 (August 1993), EN 50082-2 (March 1995), and EN 61326 Industrial.
	Ambient temperature effect	On analog outputs $\pm 0.005\%$ of span per °C

Hazardous area classifications	CSA	Class I Division 2 Groups A, B, C, D Class II Division 2 Groups F and G Class III Division 2
	ATEX	Transmitter has no ATEX classification, and should be installed only in safe areas. Transmitter outputs are acceptable for connecting to a sensor (II 3G EEx nA) in a hazardous area.

Transmitter specifications *continued*

DIN rail mount *continued*

Dimensions

Dimensions in *inches*
(*mm*)

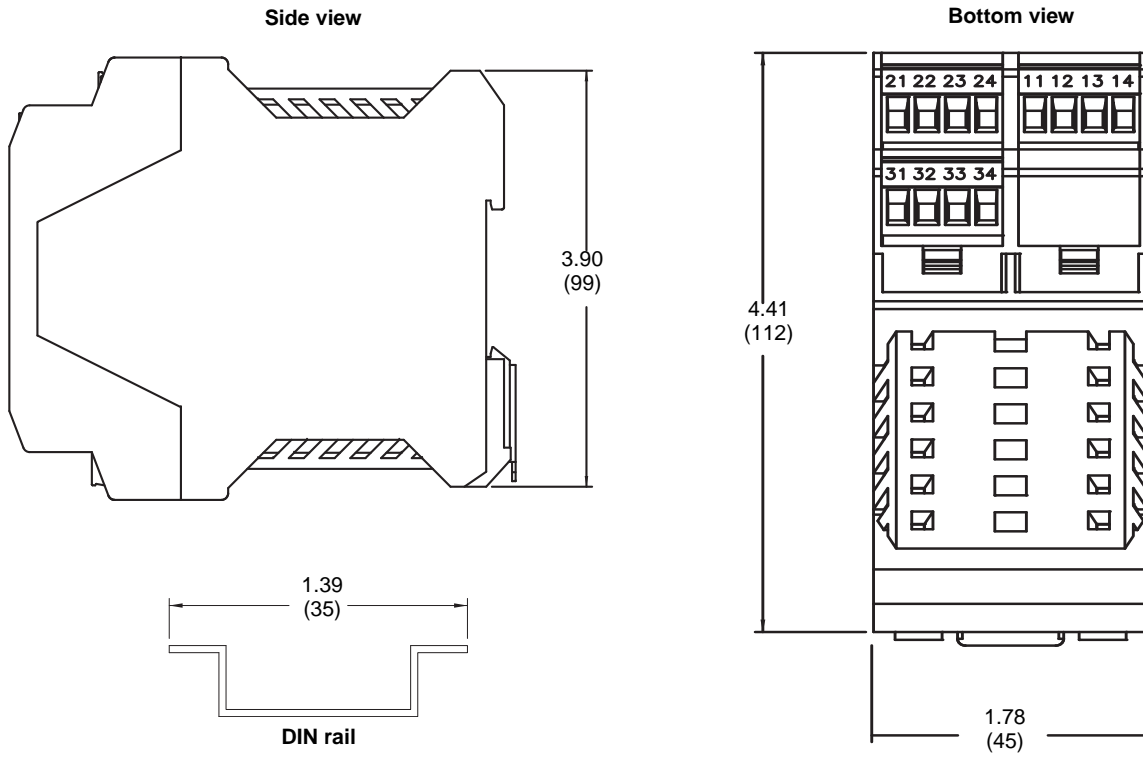

Ordering information

Sensor

Code	Product description
LF2M	Micro Motion Coriolis Low Flow sensor, 316L stainless steel
LF3M	Micro Motion Coriolis Low Flow sensor, 316L stainless steel
LF4M	Micro Motion Coriolis Low Flow sensor, 316L stainless steel
Code	Process connection
324	1/4" tube compression fittings
328	1/8" tube compression fittings
327	1/8" VCR
322	1/4" VCR
323	1/4" VCO
325	6 mm tube compression fittings
998 ⁽¹⁾	ETO fittings
Code	Surface finish
1	32 Ra
Code	Pressure rating
1	35 bar (500 psi)
2	100 bar (1500 psi)
Code	O-rings
K	Kalrez
V	Viton
B	Buna
E	EPDM
Code	Electronics interface
F	4-wire integrated core processor for remote mount transmitters (field-mount or DIN rail mount)
G	4-wire integrated core processor for direct host connection
Code	Approvals
M	Micro Motion standard (no approval)
A ⁽²⁾	CSA (U.S.A. and Canada)
L ⁽²⁾	ATEX — Equipment Category 3 (Zone 2)
Code	Language
E	English manuals
Code	Filters
A ⁽³⁾	None
B ⁽⁴⁾	10 Micron
C ⁽³⁾	20 Micron
D ⁽³⁾	30 Micron
E ⁽³⁾	40 Micron
F ⁽⁴⁾	1 Micron
Code	Calibration options
A	0.5% factory calibration
Z	No special calibration (1%)
Continued on next page	

Ordering information *continued*

Sensor *continued*

Code	Measurement application software
Z	No measurement application software
Code	Factory options
Z	Standard product
X	ETO product
Typical model number: LF4M 324 1 1 V F M E B Z Z Z	

- (1) Requires factory option X.
- (2) Electronics interface code F only.
- (3) Not available for Model LF2M.
- (4) B or F required for Model LF2M.

Transmitter

Code	Product description
LFT ⁽¹⁾	Micro Motion Coriolis Low Flow transmitter for use with LF-Series sensors
Code	Mounting and outputs
1	1 mA/1 FO flow-only 4-wire field mount transmitter
2	1 mA/1 FO flow-only 4-wire DIN rail mount transmitter
3	1 mA/1 FO multivariable 4-wire field mount transmitter
4	2 mA/1 FO configurable multivariable 4-wire field mount transmitter
5	2 mA/1 FO configurable multivariable 4-wire DIN rail mount transmitter
6	FOUNDATION fieldbus 4-wire field mount transmitter with standard fieldbus function blocks
7	PROFIBUS-PA 4-wire field mount transmitter
Code	Display
1 ⁽²⁾	Dual line display for process variables and totalizer reset
2 ⁽²⁾	Backlit dual line display for process variables and totalizer reset
3	No display
Code	Conduit connections
A ⁽³⁾	None
B ⁽²⁾	1/2" No gland
C ⁽²⁾	1/2" Brass/nickel cable gland
D ⁽²⁾	1/2" Stainless steel cable gland
E ⁽²⁾	M20 — no gland
F ⁽²⁾	M20 — brass/nickel cable gland
G ⁽²⁾	M20 — stainless steel cable gland
Code	Approvals
M	Micro Motion standard (no approval)
A	CSA (U.S.A. and Canada)
L ⁽²⁾	ATEX — Equipment Category 3 (Zone 2)
Code	Language
E	English manuals
Continued on next page	

Ordering information *continued*

Transmitter *continued*

Code	Software options
Z	Reserved for future use
Code	Software options 2
A ⁽⁴⁾	Regulatory control suite: standard fieldbus function blocks plus 1 PID block
Z	No software options 2
Code	Factory options
Z	Standard product
X	ETO product
Typical model number: LFT 1 3 A A E Z Z Z	

- (1) *This transmitter is specially designed to interface with an LF-Series sensor. LF-Series sensors are compatible only with this specific transmitter; they are not compatible with standard Micro Motion transmitters. Likewise, this transmitter is not compatible with standard Micro Motion sensors.*
- (2) *Not available with mounting and outputs code 2 or 5.*
- (3) *Mounting and outputs codes 2 and 5 only.*
- (4) *Mounting and outputs code 6 only.*

Cable

Model	PVC insulation
CLFTS ⁽¹⁾	4-wire shielded cable with Eurofast connector; braided shield
Code	Cable options
ZZ	Future expansion
Code	Cable options
010	6.5 ft (2 m)
015	20 ft (6 m)
050	50 feet (16 m)
250	200 ft (60 m)
500	500 ft (150 m)
Typical model number: CLFTS ZZ 050	

- (1) *6.5 ft (2 m) of cable with Eurofast connector ships at no charge with every LF-Series sensor. Order additional cable or longer cable as required.*

© 2007 Micro Motion, Inc. All rights reserved. PS-00566, Rev. D

Micro Motion is committed to continuous product improvement. As a result, all specifications are subject to change without notice. ELITE and ProLink are registered trademarks, and MVD and MVD Direct Connect are trademarks of Micro Motion, Inc., Boulder, Colorado. Micro Motion is a registered trade name of Micro Motion, Inc., Boulder, Colorado. The Micro Motion and Emerson logos are trademarks and service marks of Emerson Electric Co. All other trademarks are property of their respective owners.

For the latest Micro Motion product specifications, view the PRODUCTS section of our web site at www.micromotion.com

Micro Motion Inc. USA

Worldwide Headquarters
7070 Winchester Circle
Boulder, Colorado 80301
T +1 303-527-5200
+1 800-522-6277
F +1 303-530-8459

Micro Motion Europe

Emerson Process Management
Neonstraat 1
6718 WX Ede
The Netherlands
T +31 (0) 318 495 555
F +31 (0) 318 495 556

Micro Motion Asia

Emerson Process Management
1 Pandan Crescent
Singapore 128461
Republic of Singapore
T +65 6777-8211
F +65 6770-8003

Micro Motion United Kingdom

Emerson Process Management Limited
Horsfield Way
Bredbury Industrial Estate
Stockport SK6 2SU U.K.
T +44 0870 240 1978
F +44 0800 966 181

Micro Motion Japan

Emerson Process Management
1-2-5, Higashi Shinagawa
Shinagawa-ku
Tokyo 140-0002 Japan
T +81 3 5769-6803
F +81 3 5769-6844

