

Rosemount 848T Multi-Input Temperature Transmitter Family

- *Provides installation and operational savings for temperature applications*
- *Inputs are independently configurable and accept RTD, thermocouple, ohm, mV, and 4–20 mA*
- *Mounts anywhere - field hardened, intrinsically safe, and low power*
- *Interfaces to any control architectures using 3420 or 1420 gateway devices*



COMING SOON

Rosemount 848T Wireless Temperature Transmitter

The Rosemount 848T Wireless is easy to use, allowing leverage of existing practices, training, and maintenance procedures without adding wiring costs.

Consult factory for availability.

Contents

Overview: The First Choice in Temperature Monitoring	page Temperature-2
The Rosemount 848T Eight Input Temperature Transmitter	page Temperature-3
Specifications	page Temperature-4
Product Certifications	page Temperature-8
Dimensional Drawings	page Temperature-11
Ordering Information	page Temperature-14
The Rosemount 848T Wireless Temperature Transmitter	page Temperature-16
Specifications	page Temperature-17

Overview: The First Choice in Temperature Monitoring

The Rosemount 848T FOUNDATION™ fieldbus Temperature Transmitter: Simplifies and reduces the cost of a plant's process control architecture. It eliminates traditional temperature monitoring methods (wire direct, low cost single input transmitters, and multiplexers) with the introduction of this intrinsically safe, eight input transmitter that mounts beside the process. The use of FOUNDATION™ fieldbus enables a quantum leap in temperature monitoring. When combined with the Rosemount 3420 Fieldbus Interface Module, Rosemount 848T measurements can be interfaced to existing systems.

The Rosemount 848T Wireless Temperature Transmitter: Ideal for high density measurement applications. Reduces the total installed cost per wireless temperature measurement, which gives a cost effective solution in hard-to-reach or cost prohibitive locations. The Rosemount 848T Wireless is an Intrinsically Safe (I.S.) device that can be mounted practically anywhere. Each input can be configured for a variety of sensors, such as RTD, thermocouple, mV, ohm, and 4–20 mA signals.

HIGH DENSITY MEASUREMENT APPLICATIONS

Ideal for situations with multiple temperature measurements within close proximity to each other, such as distillation columns, tanks, boilers, and heat exchangers.

MOUNTS PRACTICALLY ANYWHERE

Provides optimum mounting flexibility with its ambient temperature limits, RFI immunity compliance, Intrinsic Safety approvals, and ability to mount in industrial environments.

ECONOMICAL SOLUTION

Reduces installation and operational costs by as much as 70 percent per point when compared to traditional sensor wire direct application temperature measurements.

Rosemount High Density Temperature Solutions

Rosemount 1080/1082 Multipoint Sensors

Provides multiple measurement points in one process connection using thermocouple and RTD sensors. Integrate with 848T Multi Input Temperature Transmitters for a complete solution.

3420 Fieldbus Interface Module

Provides an interface between FOUNDATION fieldbus instruments and systems without fieldbus capability using standard interface protocols.

1420 Wireless Gateway

Offers robust security, easy host integration with no additional software, and continuous network optimization to maximize data reliability and power module life of the wireless devices. Provides interface between WirelessHART field network and host systems using standard interface protocols.

The Rosemount 848T Eight Input Temperature Transmitter

ECONOMICAL SOLUTION

The Rosemount 848T offers the lowest cost solution for temperature monitoring measurements (e.g. distillation columns, tanks, reactors, boilers, etc.). It can reduce installed costs by as much as 70 percent per point when compared to traditional sensor wire direct applications.

REDUCES I.S. BARRIER COSTS

For I.S. installations, only one barrier is needed to safely power several Rosemount 848T transmitters. As a result, one barrier can support at least 24 temperature measurement points, which results in significant savings. The new Fieldbus Intrinsically Safe Concept (FISCO) certification on the Rosemount 848T allows even more measurements per I.S. segment.

EIGHT INDEPENDENT SENSOR INPUTS

The Rosemount 848T accepts eight independently configurable sensor inputs (2- and 3-wire RTDs, thermocouples, mV, and ohm).

MOUNTS PRACTICALLY ANYWHERE

The Rosemount 848T's ambient temperature limits, RFI immunity compliance, I.S. approvals, and ability to mount in industrial environments provides optimum mounting flexibility.

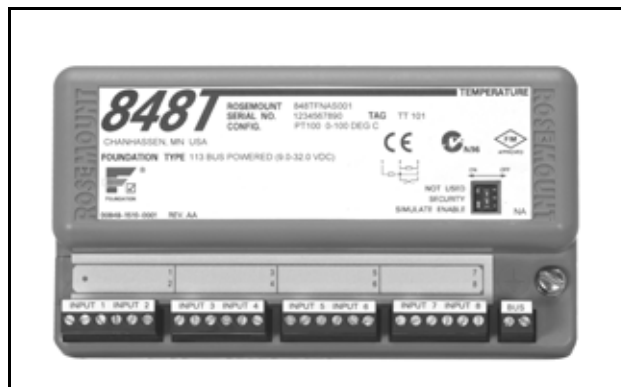

848T EIGHT INPUT TEMPERATURE TRANSMITTER

DIAGNOSTICS AND MAI FUNCTION BLOCKS

FOUNDATION fieldbus offers inherent diagnostics that provide continuous measurement status (good, bad, or uncertain) as well as sensor failure indication. The Rosemount 848T also offers the Multiple Analog Input (MAI) function block, which allows all eight sensor inputs to communicate with one function block, resulting in greater network efficiency.

CONVERTS ANALOG TO FIELDBUS

The Rosemount 848T can accept 4–20 mA inputs then outputs the value onto FOUNDATION fieldbus. The optional analog connector allows quick connection of the Field Communicator for local configuration.



The Rosemount 848T Transmitters power *PlantWeb*[®] providing multi-input devices with calculating capability using Input Selector function blocks.

Rosemount Temperature Solutions

Rosemount 644 Temperature Transmitter

Head mount styles available with *HART* or *FOUNDATION* fieldbus protocol. Rail mount style available for *HART* protocol.

Rosemount 3420 Fieldbus Interface Module

Provides an interface between *FOUNDATION* fieldbus instruments and systems without fieldbus capability using standard interface protocols.

Rosemount sensors, thermowells, and extensions

Rosemount has a broad offering of RTD and thermocouples that are designed to meet plant requirements.

Rosemount 248 Temperature Transmitter

Head mount (DIN B) and Rail mount style with *HART* protocol and complete temperature assembly.

Rosemount 3144P Temperature Transmitter

Two-compartment housing, dual sensor design available with *HART* or *FOUNDATION* fieldbus protocol.

Rosemount 148 Temperature Transmitter

Head mount style (DIN B) PC-programmable transmitter.

Specifications

FUNCTIONAL

Inputs

Eight independently configurable channels including combinations of 2- and 3-wire RTDs, thermocouples, mV, and Ω inputs.

4-20 mA inputs using optional connector(s).

All sensor terminals are rated to 42.4 VDC.

Outputs

Manchester-encoded digital signal that conforms to IEC 1158-2 and ISA 50.02.

Status

If self-diagnostics detect a sensor burnout or a transmitter failure, the status of the measurement will be updated accordingly.

Ambient Temperature Limits

-40 to 185 °F (-40 to 85 °C)

Isolation

Input/output isolation is tested to 500 VAC rms (707 VDC). Input/input isolation between each sensor input connector is tested to 500 VAC rms (707 VDC). Input/input isolation between sensors on the same input connector is 3 VAC at 50 – 60 Hz, 1.5 VDC.

Power Supply

Powered over FOUNDATION fieldbus with standard fieldbus power supplies. The transmitter operates between 9.0 and 32.0 V dc, 22 mA maximum. (Transmitter power terminals are rated to 42.4 V dc.)

Transient Protection

The transient protector (option code T1) helps to prevent damage to the transmitter from transients induced on the loop wiring by lightning, welding, heavy electrical equipment, or switch gears. This option is installed at the factory for the Rosemount 848T and is not intended for field installation.

ASME B 16.5 (ANSI)/IEEE C62.41-1991 (IEEE 587), Location Categories A2, B3.

6 kV / 3 kA peak (1.2 x 50 μ S Wave 8 x 20 μ S Combination Wave)

6 kV / 0.5 kA peak (100 kHz Ring Wave)

4 kV peak EFT (5 x 50 nS Electrical Fast Transient)

Update Time

Approximately 1.5 seconds to read all eight inputs.

Humidity Limits

0–100% non-condensing relative humidity

Turn-on Time

Performance within specifications is achieved in less than 50 seconds after power is applied to the transmitter.

Alarms

The AI and ISEL function blocks allow the user to configure the alarms to HI-HI, HI, LO, or LO-LO with a variety of priority levels and hysteresis settings.

Backup Link Active Scheduler (LAS)

The transmitter is classified as a device link master, which means it can function as a Link Active Scheduler (LAS) if the current link master device fails or is removed from the segment.

The host or other configuration tool is used to download the schedule for the application to the link master device. In the absence of a primary link master, the transmitter will claim the LAS and provide permanent control for the H1 segment.

FOUNDATION Fieldbus Parameters

Schedule Entries	25
Links	30
Virtual Communications Relationships (VCR)	20

PHYSICAL

Mounting

The Rosemount 848T can be mounted directly onto a DIN rail or it can be ordered with an optional junction box. When using the optional junction box, the transmitter can be mounted onto a panel or to a 2-in. pipe stand (with option code B6).

Entries for Optional Junction Box

No entry

- Used for custom fittings

Cable Gland

- 9 x M20 nickel-plated brass glands for 7.5–11.9 mm unarmored cable

Conduit

- 5 plugged 0.86-in. diameter holes suitable for installing $\frac{1}{2}$ -in. NPT fittings.

Materials of Construction for Optional Junction Box

Junction Box Type	Paint
Aluminum	Epoxy Resin
Plastic	NA
Stainless Steel	NA

Weight

Assembly	Weight		
	oz	lb	kg
Rosemount 848T only	9.60	0.60	0.27
Aluminum ⁽¹⁾	78.2	4.89	2.22
Plastic ⁽¹⁾	58.1	3.68	1.65
Stainless Steel ⁽¹⁾	77.0	4.81	2.18

⁽¹⁾ Add 35.2 oz (2.2 lb, 0.998 kg) for nickel-plated brass glands

Environmental Ratings

Type 4X, and CSA Enclosure Type 4X, and IP66 with optional junction box.

FUNCTION BLOCKS

Analog Input (AI)

- Processes the measurement and makes it available on the fieldbus segment.
- Allows filtering, alarming, and engineering unit changes.

Input Selector (ISEL)

- Used to select between inputs and generate an output using specific selection strategies such as minimum, maximum, midpoint, or average temperature.
- Since the temperature value always contains the measurement status, this block allows the selection to be restricted to the first "good" measurement.

Multiple Analog Input Block (MAI)

- The MAI block allows the eight AI blocks to be multiplexed together so they serve as one function block on the H1 segment, resulting in greater network efficiency.

PERFORMANCE

The transmitter maintains a specification conformance of at least $\pm 3\sigma$.

Stability

- $\pm 0.1\%$ of reading or $0.1\text{ }^\circ\text{C}$ ($0.18\text{ }^\circ\text{F}$), whichever is greater, for 2 years for RTDs.
- $\pm 0.1\%$ of reading or $0.1\text{ }^\circ\text{C}$ ($0.18\text{ }^\circ\text{F}$), whichever is greater, for 1 year for thermocouples.

Self Calibration

The transmitter's analog-to-digital circuitry automatically self-calibrates for each temperature update by comparing the dynamic measurement to extremely stable and accurate internal reference elements.

Vibration Effect

Transmitters are tested to the following vibration conditions with no effect on performance:

Frequency	Acceleration
10 - 60 Hz	0.21 mm peak displacement
60 - 2000 Hz	3 g

CE Electromagnetic Compatibility Compliance Testing

Meets the criteria under IEC 61326 Amendment 1, 2002:

Emissions
30–230 MHz, 30 dB (uV/m) at 10 m
230–1000 MHz, 37 dB (uV/m) at 10 m

Susceptibility	
ESD	4 kV contact discharge 8 kV air discharge
Radiated	80 – 1000 MHz at 10 V/m AM
Burst	1 kV
Surge	1 kV line-to-ground
Conducted	150 kHz to 80 MHz at 3V
Magnetic	50/60 Hz at 30 A/m

Rosemount 848T Family

ACCURACY

TABLE 1. Input Options/Accuracy

Sensor Option	Sensor Reference	Input Ranges		Accuracy Over Range(s)	
		°C	°F	°C	°F
2- and 3-Wire RTDs					
Pt 100 ($\alpha = 0.00385$)	IEC 751; $\alpha = 0.00385$, 1995	-200 to 850	-328 to 1562	± 0.30	± 0.54
Pt 100 ($\alpha = 0.003916$)	JIS 1604, 1981	-200 to 645	-328 to 1193	± 0.30	± 0.54
Pt 200	IEC 751; $\alpha = 0.00385$, 1995	-200 to 850	-328 to 1562	± 0.54	± 0.98
Pt 500	IEC 751; $\alpha = 0.00385$, 1995	-200 to 850	-328 to 1562	± 0.38	± 0.68
Pt 1000	IEC 751; $\alpha = 0.00385$, 1995	-200 to 300	-328 to 572	± 0.40	± 0.72
Ni 120	Edison Curve No. 7	-70 to 300	-94 to 572	± 0.30	± 0.54
Cu 10	Edison Copper Winding No. 15	-50 to 250	-58 to 482	± 3.20	± 5.76
Cu 100 (a=428)	GOST 6651-94	-185 to 200	-365 to 392	± 0.48	± 0.86
Cu 50 (a=428)	GOST 6651-94	-185 to 200	-365 to 392	± 0.96	± 1.73
Cu 100 (a=426)	GOST 6651-94	-50 to 200	-122 to 392	± 0.48	± 0.86
Cu 50 (a=426)	GOST 6651-94	-50 to 200	-122 to 392	± 0.96	± 1.73
Thermocouples —Cold Junction Adds + 0.5 °C to Listed Accuracy					
NIST Type B (Accuracy varies according to input range)	NIST Monograph 175	100 to 300 301 to 1820	212 to 572 573 to 3308	± 6.00 ± 1.54	± 10.80 ± 2.78
NIST Type E	NIST Monograph 175	-50 to 1000	-58 to 1832	± 0.40	± 0.72
NIST Type J	NIST Monograph 175	-180 to 760	-292 to 1400	± 0.70	± 1.26
NIST Type K	NIST Monograph 175	-180 to 1372	-292 to 2502	± 1.00	± 1.80
NIST Type N	NIST Monograph 175	-200 to 1300	-328 to 2372	± 1.00	± 1.80
NIST Type R	NIST Monograph 175	0 to 1768	32 to 3214	± 1.50	± 2.70
NIST Type S	NIST Monograph 175	0 to 1768	32 to 3214	± 1.40	± 2.52
NIST Type T	NIST Monograph 175	-200 to 400	-328 to 752	± 0.70	± 1.26
DIN L	DIN 43710	-200 to 900	-328 to 1652	± 0.70	± 1.26
DIN U	DIN 43710	-200 to 600	-328 to 1112	± 0.70	± 1.26
w5Re26	ASTME 988-96	0 to 2000	32 to 3632	± 1.60	± 2.88
GOST Type L	GOST R 8.585-2001	-200 to 800	-392 to 1472	± 0.71	± 1.28
Millivolt Input⁽¹⁾ —Not approved for use with CSA Option Code I6		-10 to 100 mV		± 0.05 mV	
2- and 3-Wire Ohm Input		0 to 2000 ohms		± 0.90 ohm	
Multipoint Sensors⁽²⁾					

(1) 4–20 mA inputs are scaled to 20 – 100 mV.

(2) Multipoint (up to 8 points) thermocouples and RTDs are available for purchase with the Rosemount 848T. Input ranges and accuracy for these sensors will depend on the specific multipoint sensor chosen. For more information, contact your local Emerson representative.

Accuracy Notes

Differential capability exists between any two sensor types:

For all differential configurations, the input range is X to +Y where

X = Sensor 1 minimum - Sensor 2 max.

Y = Sensor 1 maximum - Sensor 2 min.

Accuracy for differential configurations:

If sensor types are similar (for example, both RTDs or both thermocouples), the accuracy = 1.5 times worst case accuracy of either sensor type. If sensor types are dissimilar (for example, one RTD and one thermocouple), the accuracy = Sensor 1 Accuracy + Sensor 2 Accuracy.

AMBIENT TEMPERATURE EFFECT

Transmitters may be installed in locations where the ambient temperature is between -40 and 85 °C (-40 and 185 °F).

TABLE 2. Ambient Temperature Effects

NIST Type	Accuracy per 1.0 °C (1.8 °F) Change in Ambient Temperature ⁽¹⁾	Temperature Range (°C)
RTD		
Pt 100 (α = 0.00385)	• 0.003 °C (0.0054 °F)	NA
Pt 100 (α = 0.003916)	• 0.003 °C (0.0054 °F)	NA
Pt 500, Pt 1000, Ni 120	• 0.003 °C (0.0054 °F)	NA
Pt 200	• 0.004 °C (0.0072 °F)	NA
Cu 10	• 0.03 °C (0.054 °F)	NA
Cu 100 (a=428)	• 0.002 °C (0.0036 °F)	NA
Cu 50 (a=428)	• 0.004 °C (.0072 °F)	NA
Cu 100 (a=426)	• 0.002 °C (0.0036 °F)	NA
Cu 50 (a=426)	• 0.004 °C (.0072 °F)	NA
Thermocouple (R = the value of the reading)		
Type B	• 0.014 °C • 0.032 °C - (0.0025% of (R - 300)) • 0.054 °C - (0.011% of (R - 100))	• R ≥ 1000 • 300 ≤ R < 1000 • 100 ≤ R < 300
Type E	• 0.005 °C + (0.00043% of R)	• All
Type J, DIN Type L	• 0.0054 °C + (0.00029% of R) • 0.0054 °C + (0.0025% of R)	• R ≥ 0 • R < 0
Type K	• 0.0061 °C + (0.00054% of R) • 0.0061 °C + (0.0025% of R)	• R ≥ 0 • R < 0
Type N	• 0.0068 °C + (0.00036% of R)	• All
Type R, Type S	• 0.016 °C • 0.023 °C - (0.0036% of R)	• R ≥ 200 • R < 200
Type T, DIN Type U	• 0.0064 °C • 0.0064 °C - (0.0043% of R)	• R ≥ 0 • R < 0
GOST Type L	• 0.007 > 0 °C • 0.007 ± 0.003% < 0 °C	•
Millivolt	0.0005 mV	NA
2- and 3-wire Ohm	0.0084 ohms	NA

(1) Change in ambient is in reference to the calibration temperature of the transmitter (20 °C (68 °F) typical from the factory).

Ambient Temperature Notes

Examples:

When using a Pt 100 (a = 0.00385) sensor input and the transmitter is at 40 °C ambient temperature, temperature effects would be:

$$0.003 \text{ °C} \times (40 - 20) = 0.06 \text{ °C}.$$

Worst case error would be:

$$\text{Sensor Accuracy} + \text{Temperature Effects} = 0.30 \text{ °C} + 0.06 = 0.36 \text{ °C}.$$

Total Probable Error =

$$\sqrt{0.30^2 + 0.06^2} = 0.31 \text{ °C}$$

Analog to Fieldbus Performance

4– 20 mA inputs are scaled to 20 – 100 mV.

Accuracy⁽¹⁾: 0.0625% of span

Temperature Effect: [0.002% of reading + 0.000625% of span] per 1.0 °C change in Ambient Temperature.

(1) To obtain accuracy, the mV input must be calibrated while using the optional analog connector.

Product Certifications

HAZARDOUS LOCATIONS CERTIFICATION

North American Certificates

Factory Mutual (FM) Certifications

- I5** Intrinsically Safety and Non-Incendive
Intrinsically Safe Class I, Division 1 Groups A, B, C, D.
Temperature Code:
T4 ($T_a = -40$ to 60 °C)
Nonincendive for Class I, Division 2, Groups A, B, C, D.
Temperature Code:
T4A ($T_a = -40$ to 85 °C)
T5 ($T_a = -40$ to 70 °C)
When installed to Rosemount Control Drawing 00848-4402.

S002 Option is not valid with intrinsic safety (I5 and IE) approval.

- IE** FISCO (Fieldbus Intrinsically Safe Concept) Intrinsic Safety FISCO for Class I, Division 1, Groups A, B, C, D.
Temperature Code:
T4 ($T_a = -40$ to 60 °C)
Nonincendive for Class I, Division 2, Groups A, B, C, D.
Temperature Code:
T4A ($T_a = -40$ to 85 °C)
T5 ($T_a = -40$ to 70 °C)
Suitable in FISCO System when installed to Rosemount Control Drawing 00848-4402.

S002 Option is not valid with intrinsic safety (I5 and IE) approval.

TABLE 3. Entity Parameters

Power/Bus	Sensor
$U_i = 17.5$ V	$U_o = 12.02$ V
$I_i = 380$ mA	$I_o = 13.5$ mA
$P_i = 5.32$ W	$P_o = 0.04$ W
$C_i = 2.1$ nF	$C_a = 1.36$ μ F
$L_i = 0$	$L_a = 160$ mH

- N5** Dust Ignition-Proof for Use in Class II/III, Division 1, Groups E, F, G.
Nonincendive for Class I, Division 2, Groups A, B, C, D.
When installed to Rosemount Control Drawing 00848-4402.
Temperature Code:
T4A ($T_a = -40$ to 85 °C)
T5 ($T_a = -40$ to 70 °C)
Rosemount Enclosure Required.
Indoor Hazardous (Classified) Locations.

- NK** NonIncendive for Class I, Division 2, Groups A, B, C, D.
When installed to Rosemount Control Drawing 00848-4402.
Temperature Code:
T4a ($T_{amb} = -40$ to 85 °C)
T5 ($T_{amb} = -40$ to 70 °C)
Rosemount Enclosure Required.
Indoor Hazardous (Classified) Locations.

TABLE 4. FM Approved Entity Parameters⁽¹⁾

Power/Bus	Sensor
$U_i = 30$ V	$U_o = 12.02$ V
$I_i = 300$ mA	$I_o = 13.6$ mA
$P_i = 1.3$ W	$P_o = 0.04$ W
$C_i = 2.1$ nF	$C_a = 1.36$ μ F
$L_i = 0$	$L_a = 160$ mH

(1) Intrinsically safe and non-incendive parameters

Canadian Standards Association (CSA) Certifications

- E6** Explosion-Proof and Dust Ignition-Proof
Class I, Division 1, Groups B, C, and D.
Class II, Division 1, Groups E, F, and G.
Class III
Must be installed in enclosure option JX3.
Install per drawing 00848-1041.
Conduit seal not required.
- I6** Intrinsic Safety and Class I, Division 2
Class I, Division 1, Groups A, B, C, and D.
Temperature Code:
T3 ($-50 \leq T_a \leq 60$ °C)
Suitable for Class I, Division 2, Groups A, B, C, and D.
Temperature Code:
T3 ($-50 \leq T_a \leq 60$ °C)
Rated at 42.4 V dc Max.
Install per drawing 00848-4403.

S002 Option is not valid with intrinsic safety (I6 and IF) approval.

TABLE 5. CSA Approved Entity Parameters

Power/Bus	Sensor
$U_i = 30$ V	$U_o = 12.02$ V
$I_i = 300$ mA	$I_o = 11.8$ mA
$C_i = 2.1$ nF	$C_a = 1.36$ μ F
$L_i = 0$	$L_a = 225$ mH

- IF** FISCO and Class I, Division 2
Class I, Division i, groups A, B, C, and D.
Temperature Code:
T3C ($-50 \leq T_a \leq 60$ °C)
Class I, Division 2, Groups A, b, C, and D.
Temperature Code:
T3C ($-50 \leq T_a \leq 60$ °C)
FISCO Output when installed per Installation Drawing 00848-4403.

S002 Option is not valid with intrinsic safety (I6 and IF) approval.

TABLE 6. CSA Approved Entity Parameters

Power/Bus	Sensor
$U_i = 17.5 \text{ V}$	$U_o = 12.02 \text{ V}$
$I_i = 380 \text{ mA}$	$I_o = 11.8 \text{ mA}$
$C_i = 2.1 \text{ nF}$	$C_a = 1.36 \text{ }\mu\text{F}$
$L_i = 0$	$L_a = 225 \text{ mH}$

- N6 Class I, Division 2
Suitable for use in Class I, Division 2, Groups A, B, C, D, when installed per Rosemount drawing 00848-4403.
Temperature Code:
T3C = ($-50 \leq T_a \leq 60 \text{ }^\circ\text{C}$)

Must be installed in a suitable enclosure as determined acceptable by the local inspection authority.

European Certifications

CENELEC Certifications

- I1 Intrinsic Safety
Certification Number: Baseefa02ATEX0010X
ATEX Marking Ex II 1 G
EEx ia IIC T4 ($T_{\text{amb}} = -50 \text{ to } 60 \text{ }^\circ\text{C}$)
CE 1180

TABLE 7. CENELEC Approved Entity Parameters

Power/Bus	Sensor
$U_i = 30 \text{ V}$	$U_o = 12.5 \text{ V}$
$I_i = 300 \text{ mA}$	$I_o = 66 \text{ mA}$
$P_i = 1.3 \text{ W}$	$P_o = 40 \text{ mW}$
$C_i = 0$	$C_i = 0$
$L_i = 0$	$L_i = 0$

Special Conditions for Safe Use (x):

This apparatus must be installed in an enclosure which affords it a degree of protection of at least IP20. Non-metallic enclosures must have a surface resistance of less than 1G ohm, light alloy or zirconium enclosures must be protected from impact and friction when installed.

The apparatus will not meet the 500V rms isolation test required by Clause 6.4.12 on EN50 020:1994. This must be taken into account when installing the apparatus.

- IA FISCO (Fieldbus Intrinsically Safe Concept) Intrinsic Safety
Certification Number: Baseefa02ATEX0010X
ATEX Marking Ex II 1 G
EEx ia IIC T4 ($T_{\text{amb}} = -50 \text{ to } 60 \text{ }^\circ\text{C}$)
CE 1180

TABLE 8. CENELEC Approved Entity Parameters

Power/Bus	Sensor
$U_i = 17.5 \text{ V}$	$U_o = 12.5 \text{ V}$
$I_i = 380 \text{ mA}$	$I_o = 66 \text{ mA}$
$P_i = 5.32 \text{ W}$	$P_o = 40 \text{ mW}$
$C_i = 0$	$C_i = 0$
$L_i = 0$	$L_i = 0$

Special Conditions for Safe Use (x):

This apparatus must be installed in an enclosure which affords it a degree of protection of at least IP20. Non-metallic enclosures must have a surface resistance of less than 1G ohm, light alloy or zirconium enclosures must be protected from impact and friction when installed.

The apparatus will not meet the 500V rms isolation test required by Clause 6.4.12 on EN50 020:1994. This must be taken into account when installing the apparatus.

- N1 CENELEC Type n
Certification Number: BAS01ATEX3199X
ATEX Marking Ex II 3 G
EEx nL IIC T5 ($T_{\text{amb}} = -40 \text{ to } 65 \text{ }^\circ\text{C}$)

TABLE 9. Entity Parameters

Power/Bus	Sensor
$U_i = 42.4 \text{ V}$	$U_o = 5 \text{ V}$
$C_i = 0$	$I_o = 2.5 \text{ mA}$
$L_i = 0$	$C_o = 1000 \text{ }\mu\text{F}$
	$L_o = 1000 \text{ mH}$

Special Conditions for Safe Use (x):

- Provisions shall be made, external to the apparatus, to prevent the rated voltage (42.4 V dc) being exceeded by transient disturbances of more than 40%.
- The ambient temperature range of use shall be the most restrictive of the apparatus, cable gland, or blanking plug.

- NC CENELEC Type n Component
Certification Number: BAS01ATEX3198U
ATEX Marking Ex II 3 G
EEx nL IIC T4 ($T_{\text{amb}} = -50 \text{ to } 85 \text{ }^\circ\text{C}$)
EEx nL IIC T5 ($T_{\text{amb}} = -50 \text{ to } 70 \text{ }^\circ\text{C}$)

Special Conditions for Safe Use (x):

- The component must be housed in a suitably certified enclosure.
- Provision shall be made, external to the component, to prevent the rated voltage (42.4V d.c.) being exceeded by transient disturbances of more than 40%.

- ND CENELEC Dust Ignition Proof
Certification Number: BAS01ATEX1315X
ATEX Marking Ex II 1 D
T90C ($T_{\text{amb}} = -40 \text{ to } 65 \text{ }^\circ\text{C}$) IP66

Special Conditions for Safe Use (x):

- The user must ensure that the maximum rated voltage and current (42.2 volts, 22 mA, DC) are not exceeded. All connections to other apparatus or associated apparatus shall have control over this voltage and current equivalent to a category "ib" circuit according to EN50020.
- Component approved EEx e cable entries must be used which maintain the ingress protection of the enclosure to at least IP66.
- Any unused cable entry holes must be filled with component approved EEx e blanking plugs.
- The ambient temperature range of use shall be the most restrictive of the apparatus, cable gland, or blanking plug.

Rosemount 848T Family

NE BASEEFA/CENELEC ATEX TYPE 'n' APPROVAL
 Certification Number: BAS01ATEX3199X
 ATEX Marking  II 3 G
 EEx nA nL IIC T5 (T_{amb} = -40 to 65 °C)
 NOTE: NE is valid with S001 Input Type ONLY.

TABLE 10. Baseefa Approved Entity Parameters

Power/Bus	Sensor
U _i = 42.4 V	U _o = 5 V dc
C _i = 0	I _o = 2.5 mA
L _i = 0	C _o = 1000 µF
	L _o = 1000 mH

Special Conditions of Safe Use (x):

- Provisions shall be made, external to the apparatus, to prevent the rated voltage (42.2V dc) being exceeded by transient disturbances of more than 40%.
- The ambient temperature range of use shall be the most restrictive of the apparatus, cable gland or blanking plug.

NF COMPONENT Approval
 Certification Number: BAS01ATEX3198U
 ATEX Marking  II 3 G
 EEx nA nL IIC T4 (T_{amb} = -50 to 85 °C)
 EEx nA nL IIC T5 (T_{amb} = -50 to 70 °C)
 NOTE: NF is valid with S001 Input Type ONLY..

TABLE 11. Baseefa Approved Entity Parameters

Power/Bus	Sensor
U _i = 42.4 V	U _o = 5 V dc
C _i = 0	I _o = 2.5 mA
L _i = 0	C _o = 1000 µF
	L _o = 1000 mH

Special Conditions of Safe Use (x):

- The component must be housed in a suitable certified enclosure.
- Same as condition 1 for Cert: BAS01ATEX3198U

Australian Certifications

Standard Australia Quality Assurance Service (SAA)

NOTE

Consult factory for SAA availability.

- I7 Intrinsic Safety
 Ex ia IIC T4 (T_{amb} = - 40 to 60 °C)
- IG IECEX FISCO
 Ex ia IIC T4 (T_{amb} = - 40 to 60 °C)
- N7 Type n
 Ex n IIC T4 (T_{amb} = - 50 to 85 °C)
 Ex n IIC T5 (T_{amb} = - 50 to 70 °C)

Conditions of Safe Use (x):

- The 848T shall be used according to its input and output parameters.
- For Ex ia applications, the equipment is to be DIN-rail mounted in an IP20 area, mounted in a Rosemount Junction Box Option Code JPx, JAx, or JSx, or mounted in any suitable enclosure rated to a minimum of IP20.

- For Ex n applications, the equipment is to be mounted in a Rosemount Junction Box Option Code JPx, JAx, or JSx, or mounted in any suitable enclosure rated to a minimum of IP54.
- When installed in an enclosure, cable glands are to be selected and used to ensure a minimum rating of IP20 for Ex ia equipment or a minimum rating of IP54 for Ex n equipment. Unused cable glands or conduit entries are to be closed to ensure the required IP rating is maintained.
- When the equipment is to be installed and used in accordance with the FISCO concept, the transient protection option is to be fitted.
- The sensor terminals are for use with passive temperature sensors only (resistance or thermocouple) that are classed as simple devices.

Brazilian Certifications

Centro de Pesquisas de Energia Eletrica (CEPEL) Approval

NOTE

Consult factory for CEPEL availability.

Dimensional Drawings

Junction Boxes with no entries (option codes JP1, JA1, and JS1)– external dimensions are the same as those outlined for the other junction box materials in this section.

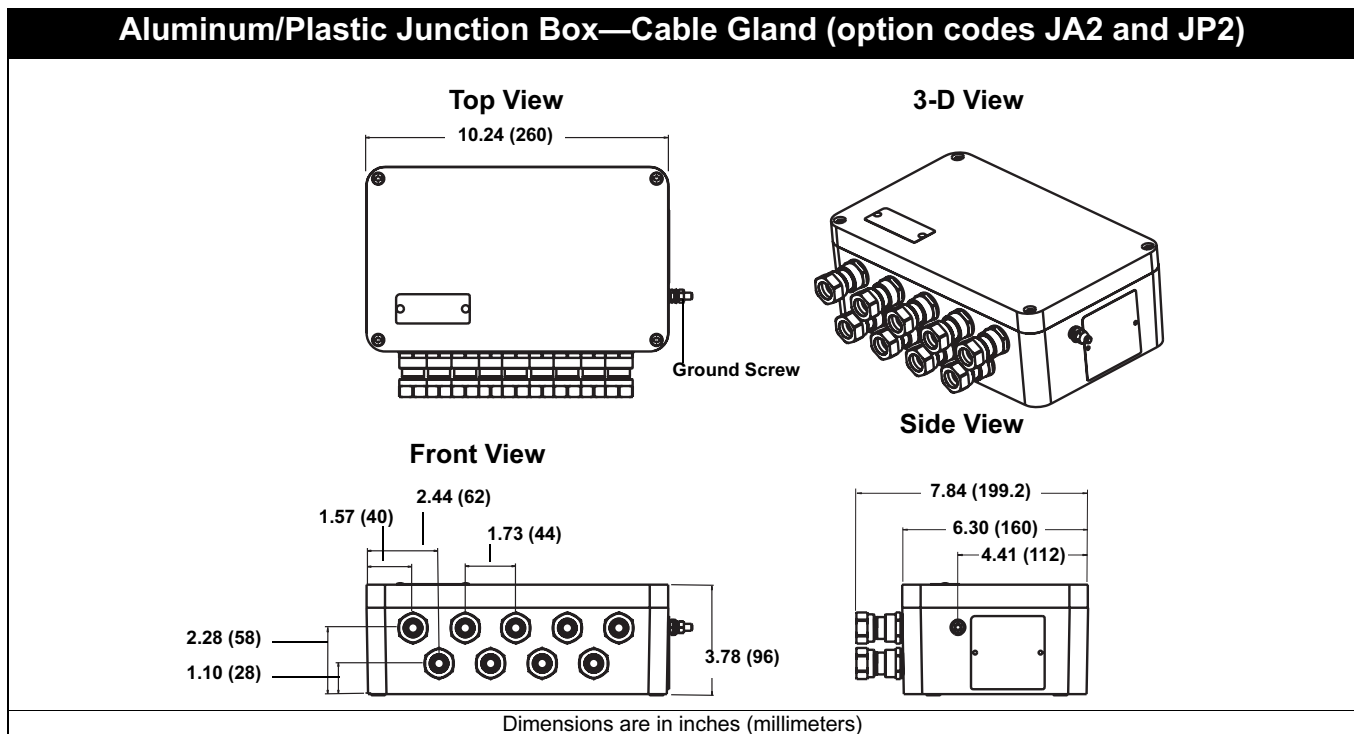
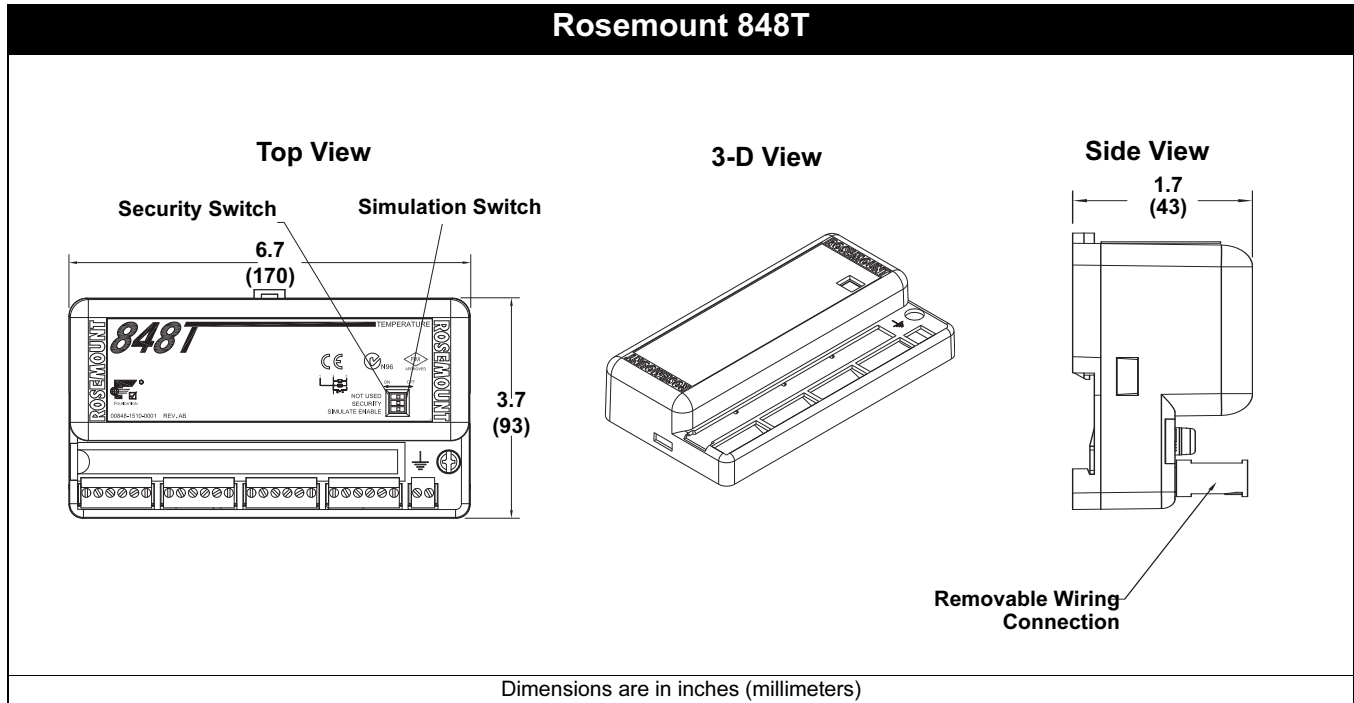

Stainless Steel Junction Box—Cable Gland (option code JS2)

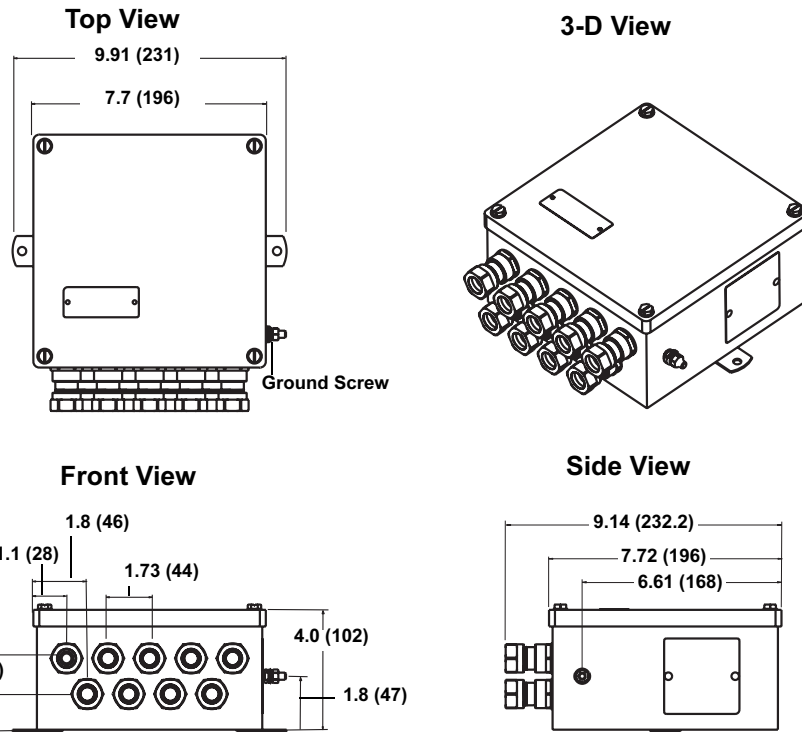

Dimensions are in inches (millimeters)

Aluminum/Plastic Junction Box—Conduit Entry (option codes JA3 and JP3)

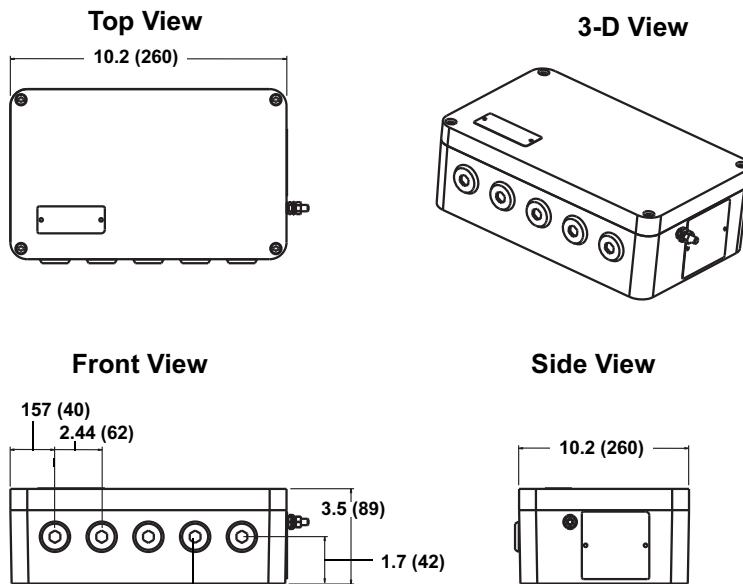

Five Plugged 0.86-in. diameter holes suitable for installing 1/2-in. NPT fittings

Dimensions are in inches (millimeters)

Stainless Steel Junction Box—Conduit Entry (option code JS3)

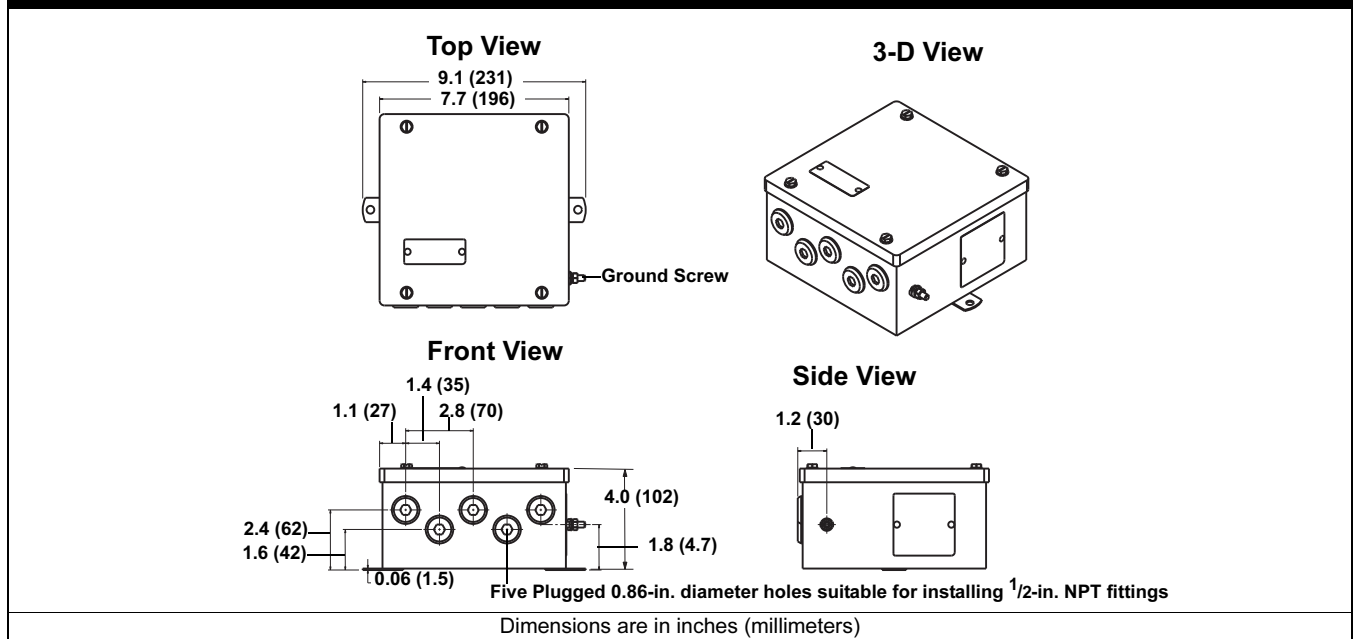

MOUNTING OPTIONS

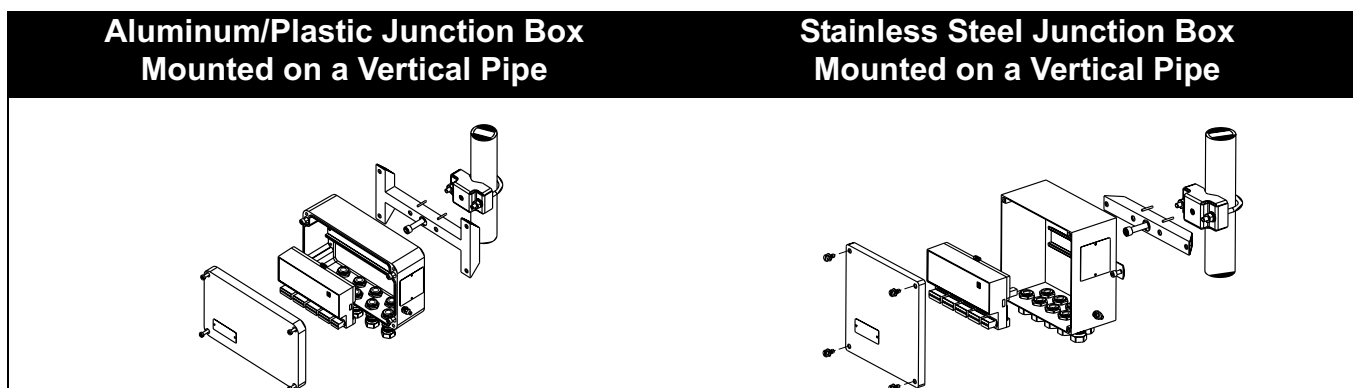
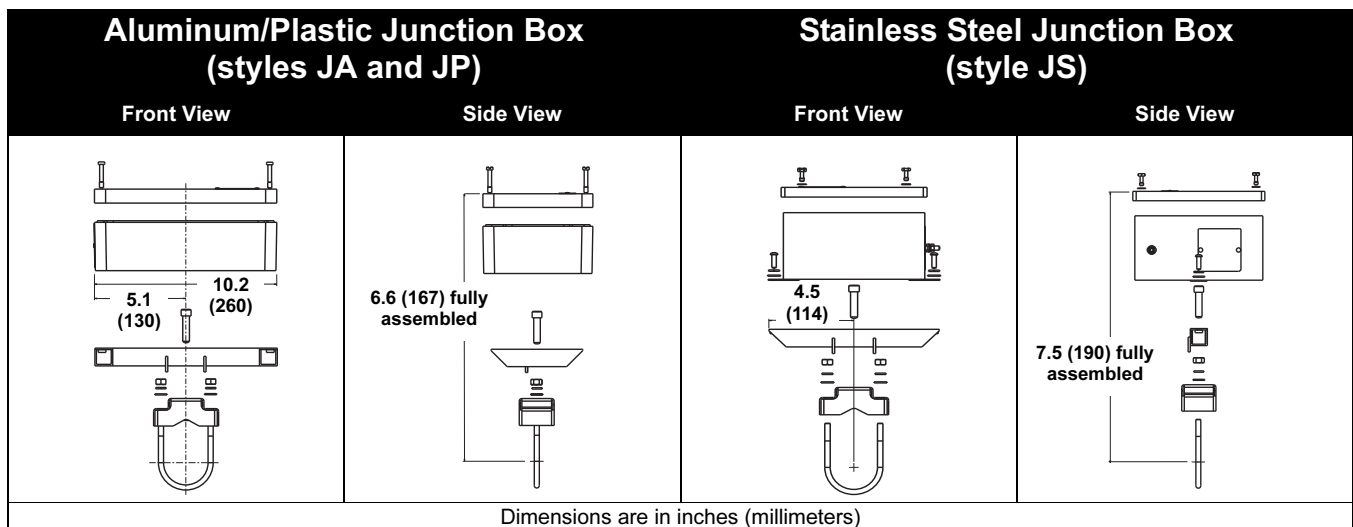

Ordering Information

Model	Product Description	
848T	Multisensor Transmitter Temperature Inputs	
Code	Communications Protocol	
F	FOUNDATION™ fieldbus digital signal (includes AI, MAI, and ISEL function blocks, and Backup Link Active Scheduler)	
Code	Product Certifications ⁽¹⁾	Rosemount Junction Box required?
I5 ⁽⁴⁾	FM Intrinsic Safety and Non-Incendive, Class 1, Division 2	No
IE	FM FISCO (Fieldbus Intrinsically Safe Concept) and Non-Incendive Class 1, Division 2	No
N5	FM Class I, Division 2, and Dust Ignition Proof	Yes
E6	CSA Explosion-Proof Approval and Dust Ignition Proof	Yes ⁽²⁾
I6 ⁽⁴⁾	CSA Intrinsic Safety and Non-Incendive, Class 1, Division 2	No
IF ⁽⁴⁾	CSA FISCO (Fieldbus Intrinsically Safe Concept) and suitable for Class I, Division 2	No
N6	CSA Class I, Division 2	No
I1	ATEX Intrinsic Safety	No
IA	ATEX FISCO (Fieldbus Intrinsically Safe Concept)	No
N1	ATEX Type n (EEx nL)	Yes
NC	ATEX Type n Component (EEx nL)	No ⁽³⁾
ND	ATEX Dust Ignition Proof	Yes
NE ⁽⁴⁾	ATEX Type n (EEx nA nL)	Yes
NF ⁽⁴⁾	ATEX Type n Component (EEx nA nL)	No ⁽³⁾
I7	IECEx Intrinsic Safety	No
IG	IECEx FISCO (Fieldbus Intrinsically Safe Concept)	No
N7	IECEx Type n (Ex nA nL)	Yes
NJ	IECEx Type n Component (Ex nA nL)	No ⁽³⁾
NK	FM Class 1, Division 2	No
NA	No Approval	No
Code	Input Types	
S001	Resistance Temperature Detectors and Thermocouples	
S002 ⁽⁵⁾	RTDs, Thermocouples, and 4–20 mA	
Code	Options	
Transient Protection		
T1	Transient Protection	
Mounting Kit Options		
B6	Mounting Bracket for 2-in. pipe mounting and for panel mounting – SST bracket and bolts	
Enclosure Options		
JP1	Plastic Junction Box; No Entries	
JP2	Plastic Box, Cable Glands (9 x M20 nickel-plated brass glands for 7.5–11.9 mm unarmored cable)	
JP3	Plastic Box, Conduit Entries (5 plugged holes, suitable for installing 1/2-in. NPT fittings)	
JA1	Aluminum Junction Box; No Entries	
JA2	Aluminum Cable Glands (9 x M20 nickel-plated brass glands for 7.5–11.9 mm unarmored cable)	
JA3	Aluminum Conduit Entries (5 plugged holes, suitable for installing 1/2-in. NPT fittings)	
JS1	Stainless Steel Junction Box; No Entries	
JS2	Stainless Steel Box, Cable Glands (9 x M20 nickel-plated brass glands for 7.5–11.9 mm unarmored cable)	
JS3	Stainless Steel Box, Conduit Entries (5 plugged holes, suitable for installing 1/2-in. NPT fittings)	
JX3	Explosion-Proof Box, Conduit Entries (4 plugged holes, suitable for installing 1/2-in. NPT fittings)	
Custom Software Configuration Request		
C1	Factory configuration of date, descriptor, and message fields (CDS required)	

Options continued on next page

Model	Product Description
Configuration Options⁽⁶⁾	
F5	50 Hz Line Voltage Filter
Calibration Certification	
Q4	3 Point Calibration Certificate Provided
Conduit Electrical Connector	
GE ⁽⁷⁾	M12, 4-pin, Male Connector (eurofast [®])
GM ⁽⁷⁾	A size Mini, 4-pin, Male Connector (minifast [®])
Typical Model Number: 848T F I5 S001 T1 B6 JA2	

- (1) Consult factory for availability.
- (2) Enclosure Option JX3 must be ordered with Product Certification Code E6.
- (3) The Rosemount 848T ordered with component approval is not approved as a stand-alone unit. Additional system certification is required.
- (4) Available only with S001 option
- (5) S002 is only available with Product Certification N5, N6, N1, NC, Nk, and NA.
- (6) Configuration is the same for all eight inputs.
- (7) Available with no approval or Intrinsically Safe approvals only. For FM Intrinsically Safe (option code I5), install in accordance with Rosemount drawing 00848-4402.

Transmitter Tag

Hardware

- tagged in accordance with customer requirements
- permanently attached to the transmitter

Software

- the transmitter can store up to 30 characters
- if no characters are specified, the first 30 characters of the hardware tag will be used

Sensor Tag

Hardware

- a provided plastic tag to record identification of eight sensors
- this information can be printed at the factory upon request
- in the field, the tag can be removed, printed onto, and reattached to the transmitter

Software

- if sensor tagging is requested, the Sensor Transducer Block sensor_sn parameters will be set at the factory
- the sensor_sn parameters can be updated in the field

Wiring

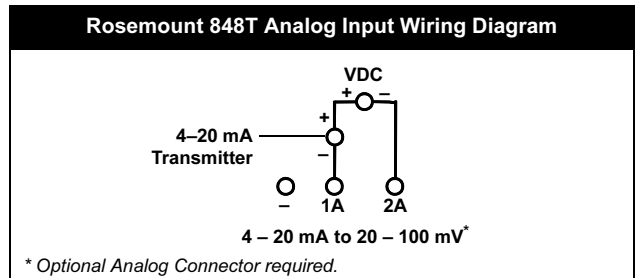
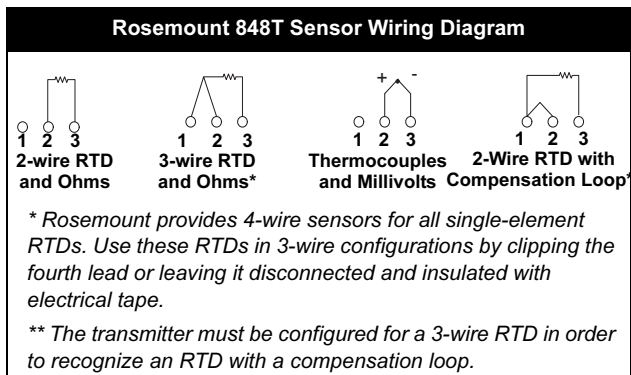

Transmitter Configuration

The transmitter is available with the standard configuration setting. The configuration settings and block configuration may be changed in the field with the Fisher-Rosemount Systems DeltaV[®], with AMSinside, or other FOUNDATION fieldbus host or configuration tool.

Standard Configuration

Unless otherwise specified, the transmitter will be shipped as follows for all eight sensors:

Standard Configuration Settings	
Sensor Type ⁽¹⁾	Thermocouple Type J
Damping ⁽¹⁾	5 seconds
Measurement Units ⁽¹⁾	°C
Output ⁽¹⁾	Linear with Temperature
Line Voltage Filter ⁽¹⁾	60 Hz
Temperature Specific Blocks	<ul style="list-style-type: none"> • Measurement Transducer Block (1) • Sensor Transducer Block (8) • Differential Transducer Block (4)
FOUNDATION™ fieldbus Function Blocks	<ul style="list-style-type: none"> • Analog Input (8) • Multiple Analog Input (1) • Input Selector (4)

(1) For all eight sensors

Coming Soon

The Rosemount 848T Wireless Temperature Transmitter

HIGH DENSITY MEASUREMENT APPLICATIONS

Ideal for situations with multiple temperature measurements within close proximity to each other, such as distillation columns, tanks, boilers, and heat exchangers.

SELF-ORGANIZING NETWORKS

Intelligent devices that provide exceptional data reliability and network stability. The Rosemount 848T Wireless is easy to use, allowing you to leverage existing practices, training and maintenance procedures, without adding wiring costs.

LAYERED SECURITY FOR NETWORK SAFETY

Emerson Process Management's layered approach to wireless network security ensures that your networks stays protected. The network devices implement Encryption, Authentication, Verification, Anti-Jamming and Key Management methods to ensure data transmissions are received only by the Wireless Gateway.

CONFIGURABLE ALERTS

The 848T Wireless has four different alert levels configurable by the user. Alerts can be sent when the temperature readings rise above or fall below the user-defined temperature range. Improvements to product quality or asset performance can be made with four user configurable alerts.



848T WIRELESS TEMPERATURE TRANSMITTER

SMARTPOWER™

Rosemount devices incorporate SmartPower™. SmartPower™ refers to the benefits that users enjoy due to the engineering efforts made to reduce power consumption. Emerson has power-optimized our instrumentation, both hardware and software, to extend power module life while still delivering highly reliable measurements with rich HART data and diagnostic information.

DIGITAL FIELD DEVICES THAT POWER PLANTWEB



The Rosemount 848T Wireless powers *PlantWeb*® by communicating temperature diagnostics and *PlantWeb* alerts that ensure process health and enable economical multi-sensor architecture.

Smart Wireless Solutions

Rosemount 648 Wireless Temperature Transmitter

The 648 integrates temperature measurement into a self-organizing network to optimize plant performance while minimizing maintenance.

1420 Wireless Gateway

The 1420 enables the most robust security available, easy host integration with no additional software, and is continuously optimizing network performance to maximize data reliability and power module life of the wireless devices.

Rosemount 3051S Wireless Series

The scaleable 3051S integrates pressure, flow, and level measurements into a self-organizing network solution to optimize plant performance and reduce risk.

Rosemount 702 Discrete Input Transmitter

The 702 integrates discrete measurements into a self-organizing network, and accepts single or dual switch inputs.

Specifications

FUNCTIONAL

Inputs

Supports up to 4 thermocouple, 2-, 3-, and 4-wire RTD, mV, ohm, and 4–20 mA input types.

Outputs

2.4 GHz DSSS WirelessHART, linear with temperature or input.

Humidity Limits

0–100% relative humidity

Transmit Rate

User selectable, 15 seconds to 60 minutes.

Accuracy

PT100 @ reference conditions 20 °C: ± 0.30 °C (± 0.54 °F).

PHYSICAL

Electrical Connections

Wireless Power Module

Intrinsically Safe, Field Replaceable Lithium-thionyl Chloride power module. Ten year life at reference conditions.⁽¹⁾

Sensor Terminals

Screw terminals permanently fixed to the terminal block.

HART Communicator Connections

Communication Terminals

Clips permanently fixed to terminal block.

Materials of Construction

Enclosure

Housing - Low-copper aluminum

Paint - Polyurethane

Cover O-ring - TBD

Mounting

Transmitter can be mounted onto a panel or 2-inch pipe stand.

Sensors must be remotely mounted.

Enclosure Rating

Type 4X; IP65.

(1) Reference conditions are 77 °F (25 °C) and transmit rate of once every 4 minutes.

Rosemount 848T Family

Product Data Sheet
00813-0100-4697, Rev GA
Catalog 2008 - 2009

*The Emerson logo is a trademark and service mark of Emerson Electric Co.
Rosemount and the Rosemount logotype are registered trademarks of Rosemount Inc.
HART is a registered trademark of the HART Communication Foundation.
FOUNDATION is a trademark of the Fieldbus Foundation.
DeltaV is a mark of one of the Emerson Process Management companies.
All other marks are the property of their respective owners.*

Standard Terms and Conditions of Sale can be found at www.rosemount.com/terms_of_sale

Emerson Process Management

Rosemount Inc.

8200 Market Boulevard
Chanhassen, MN 55317 USA
T (U.S.) 1-800-999-9307
T (International) (952) 906-8888
F (952) 949-7001

www.rosemount.com



Emerson Process Management

Heath Place
Bognor Regis
West Sussex PO22 9SH
England
Tel 44 (1243) 863 121
Fax 44 (1243) 867 554

Emerson Process Management Asia Pacific Private Limited

1 Pandan Crescent
Singapore 128461
T (65) 6777 8211
F (65) 6777 0947
Enquiries@AP.EmersonProcess.com