

NEMA 4X and IP66 Mass Flow Controllers and Meters

Mfi Series

Controllers: Mf50*i*, Mf51*i* and Mf53*i*

Meters: Mf60*i*, Mf61*i* and Mf63*i*

Mfx Series

Controllers: Mf50x, Mf51x and Mf53x

Meters: Mf60x, Mf61x and Mf63x

- NEMA 4X, IP66 watertight construction
- UL and cUL listed and recognized for Class I Division 2 hazardous locations (Mfx)
- Wide FS flow range for measurement and control of gases from 3 sccm to 1000 slpm N₂ (control) and 1000 slpm N₂ (measurement)
 - Flow control to 1000 slpm N₂
 - Flow metering to 1000 slpm N₂
- Sensor: Removable (Mfi) / Welded (Mfx)
- Insensitive to mounting attitude
- Selectable response time
- Electrically activated valve override
- Low command flow cutoff
- Corrosion resistant valve

DESCRIPTION

The Brooks® Mf Series mass flow controllers and flowmeters are specifically designed to be used in an industrial environment. These controllers and meters offer high accuracy, control and measurement of industrial gases with the added integrity of NEMA 4X, IP66 industrial packaging. Additionally, the Mfx Series offers Class I Division 2 hazardous location approval. The heart of the controller and meter is the removable flow sensor which produces an electrical output signal linear with mass flow rate. This output can be used for indicating, recording and/or control purposes. The Brooks Mf Series Mass Flow Controller has an integral valve and accepts a remote setpoint which makes it a simple and easy to install flow control system. Many options are offered to provide a versatile system of mass flow control and measurement.

The control circuitry compares the command setpoint to the flow signal and positions the precision solenoid control valve. When the command signal is below 1% of full scale, the control valve is positioned to fully closed. The control valve can be latched fully open or closed by activating the valve override circuit.



SPECIFICATIONS

Performance Characteristics:

Table 1 Flow Ranges

Mass Flow Controller	Mass Flow Meter	Flow Ranges Nitrogen*			PED Module H
Model	Model	Min. F. S.	Max. F. S. (slpm)	Max. Press. psi (Bar)	SEP
Mf50	Mf60	0.003	30	1500 (100)	
N/A	Mf60	0.003	30	4500 (300)	
Mf51	Mf63	10	100	1000 (68)	
Mf53	N/A	100	1000	1000 (68)	

* Standard temperature and pressure equals 0°C and 101kPa (760 Torr). These mass flow controllers and meters can be calibrated to other conditions. Specify at time of ordering.

** Refer to Table 2 for standard flow ranges which are based on the meter/pipe size from 1-1/2 inches through 8 inches.

Control/Usable Range

50 to 1

Accuracy

±1% full scale including linearity at calibrated conditions

Repeatability

0.25% of rate

Sensitivity to Mounting Attitude

±0.5% full scale maximum deviation from specified accuracy after re-zeroing under 200 psig. Specify mounting attitude at time of order to insure optimum performance.

Brooks® Mf Series

Temperature Sensitivity

Zero: Less than $\pm 0.075\%$ F.S. per degree C
Span: Less than $\pm 1.0\%$ F.S. shift from original calibration over 50°F to 122°F range (10°C to 50°C)

Pressure Sensitivity

$\pm 0.03\%$ per psi up to 200 psig (N₂)

Ratings:

Operating Pressure

Refer to Table 1
Consult factory for higher pressure ratings.

Differential Pressure (Controllers)

Mf50: 5 to 50 psid pressure drop
Mf51: 10 to 50 psid pressure drop
Mf53 Standard high differential valve 30 to 290 psid
Optional: Low differential valve 7.5 to 30 psid (<500 slpm)
11.8 to 30 psid (>500 slpm)

Response Time

Less than 6 seconds to within 2% of full scale of final value for a 0 to 100% command change.

Temperature Ambient/Gas

41°F to 149°F (5°C to 65°C)

Leak Integrity, Outboard

1 x 10⁻⁹ atm cc/sec. He (excluding permeation)

Physical Characteristics:

Materials of Construction

Standard wetted parts: Stainless steel with Viton® fluoroelastomers or Buna-N
Optional: Kalrez®

Dimensions

Controllers: Refer to Figures 4-7
Meters: Refer to Figures 8-11

Process Connections

Refer to the table at the bottom of each dimensional drawing for process connection sizes and options specific to each size controller and meter.

ELECTRICAL SPECIFICATIONS

Set Point Command Requirements (Controllers)

4-20 mA (75 ohms input resistance) or 0 to 5 Vdc (220 K ohms input resistance).

Output Signals

0/4-20 mA, loop resistance is power supply dependent, refer to Figure 1, or 0 to 5 Vdc into 200 K ohms, or greater load. Maximum ripple 3 mV.

Power Requirements

Refer to Table 2.

Electrical Connections

Wire hookup is through a Pg11 water tight cable gland suitable for cable diameters of .20 to .39 inches. Wiring termination's are pluggable moving vise clamp with screw type terminations. Refer to Figure 2 for termination points and Table 3 for terminal identification and functions.

Typical Electrical Configuration

Figure 3 illustrates typical electrical hookup to Brooks 0151i Power Supply/Set Point Controller/Readout.

Table 2 Power Requirements

Mass Flow Controllers			Mass Flow Meters		
Model	Voltage	Current	Model	Voltage	Current
Mf50	15 to 28 Vdc	240 mA @ 15 Vdc	Mf60	15 to 28 Vdc	90 mA
		370 mA @ 28 Vdc			
Mf51**	15 to 28 Vdc	309 mA @ 22 Vdc	Mf61	15 to 28 Vdc	90 mA
		370 mA @ 28 Vdc			
Mf53	15 to 28 Vdc	240 mA @ 15 Vdc	Mf63	15 to 28 Vdc	90 mA
		370 mA @ 28 Vdc			

** Note minimum voltage for Mf51 is 22 Vdc

Approximate Shipping Weights (lbs.)

Model	Weight	Model	Weight
Mf50	10	Mf60	6
Mf51	11	Mf61	8
Mf53	20	Mf63	18

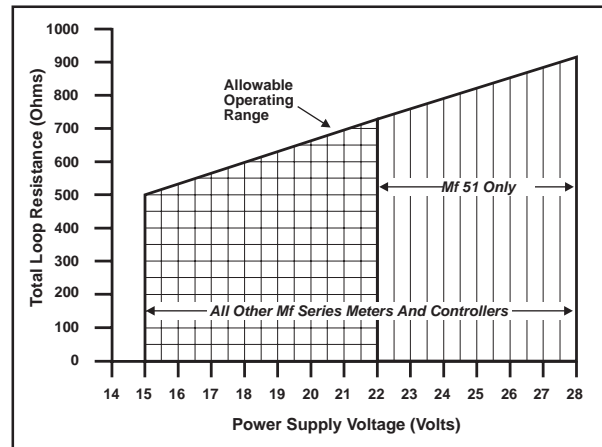

Figure 1 Maximum Allowable Loop Resistance

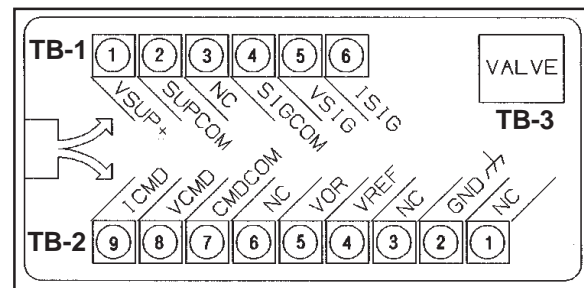

Figure 2 Terminal Strip Labeling

Data Sheet

DS-TMF-Mfi-Mfx-MFC-eng

March, 2008

Brooks® Mf Series

Certifications:

EMC Directive 89/336/EEC:

Per EN 61326

Hazardous Location Classification

Non-Incendive

Enclosure Type 4X 1/IP66

Ambient Temperature: 5°C > Tamb < 65°C (T3C) or
5°C > Tamb < 55°C (T4)

United States and Canada

UL Listed: E73889 Volume 1, Section 17

UL Recognized: E73889 Volume 3, Section 1



Class I, Division 2, Groups A, B, C and D;
Class II, Division 2, Groups F and G;
Suitable for Class III, Division 2

Per UL 1604 and CSA-213

Pressure Equipment Directive (97/23/EC)

See pressure Table 1 for further information

Table 3 Mf Series Controllers and Meters Terminal Strip Hookup

TB-1 Terminal 1-6	Label Identification	Function	Color Code**
1	VSUP	Supply Voltage Plus (+) See Table 3	Orange
2	SUPCOM	Supply Voltage Common	Grn/Blk
3	NC	Not Used	Blue
4	SUPCOM	Signal Common	Org/Blk
5	VSIG	Voltage Signal Output	White
6	ISIG	Current Signal Output	Green
TB-2 Terminal 1-9	Label Identification	Function	Color Code**
1	NC	Not Used	Blu/Wht
2	GND	Chasis Ground	Grn/Wht
3	NC	Not Used	Red
4	VREF	Reference Output +5 Vdc	Blu/Blk
5	VOR	Valve Override Input	Blk/Wht*
6	NC	Not Used	Red/Wht
7	CMDCOM	Command Common	Black*
8	VCMD	Voltage Command Input (Setpoint)	Red/Blk*
9	ICMD	Current Command Input (Setpoint)	Wht/Blk*
TB-3 Terminal 1 & 2	Label Identification	Function	Color Code**
1	NONE	Valve Hookup	Orange*
2	NONE	Valve Hookup	Orange*

* These connections used only for controllers (Models Mf50, Mf51 and Mf53)

** Brooks reference

Brooks® Mf Series

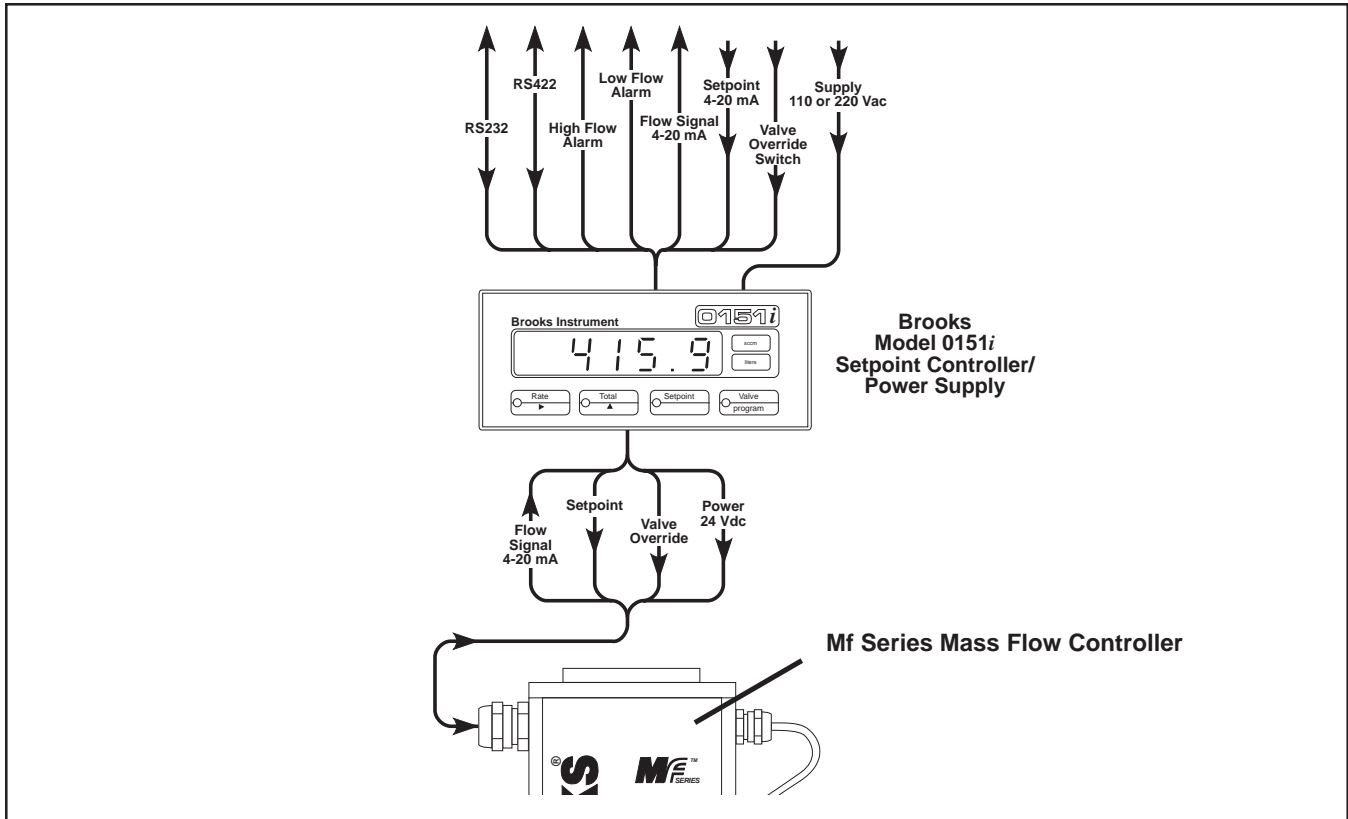

Figure 3 Model Mf Series Block Diagram

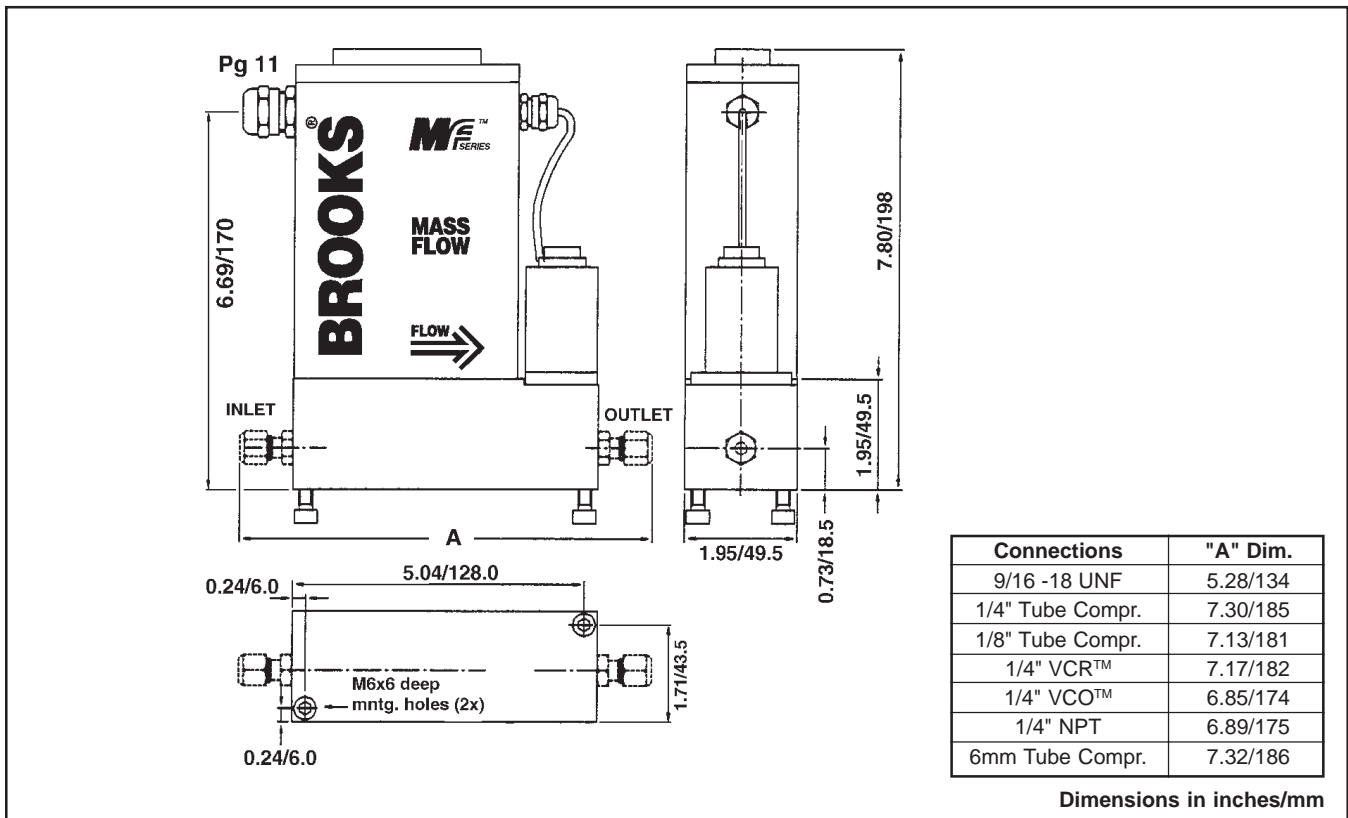

Figure 4 Model Mf50 Controller Dimensions

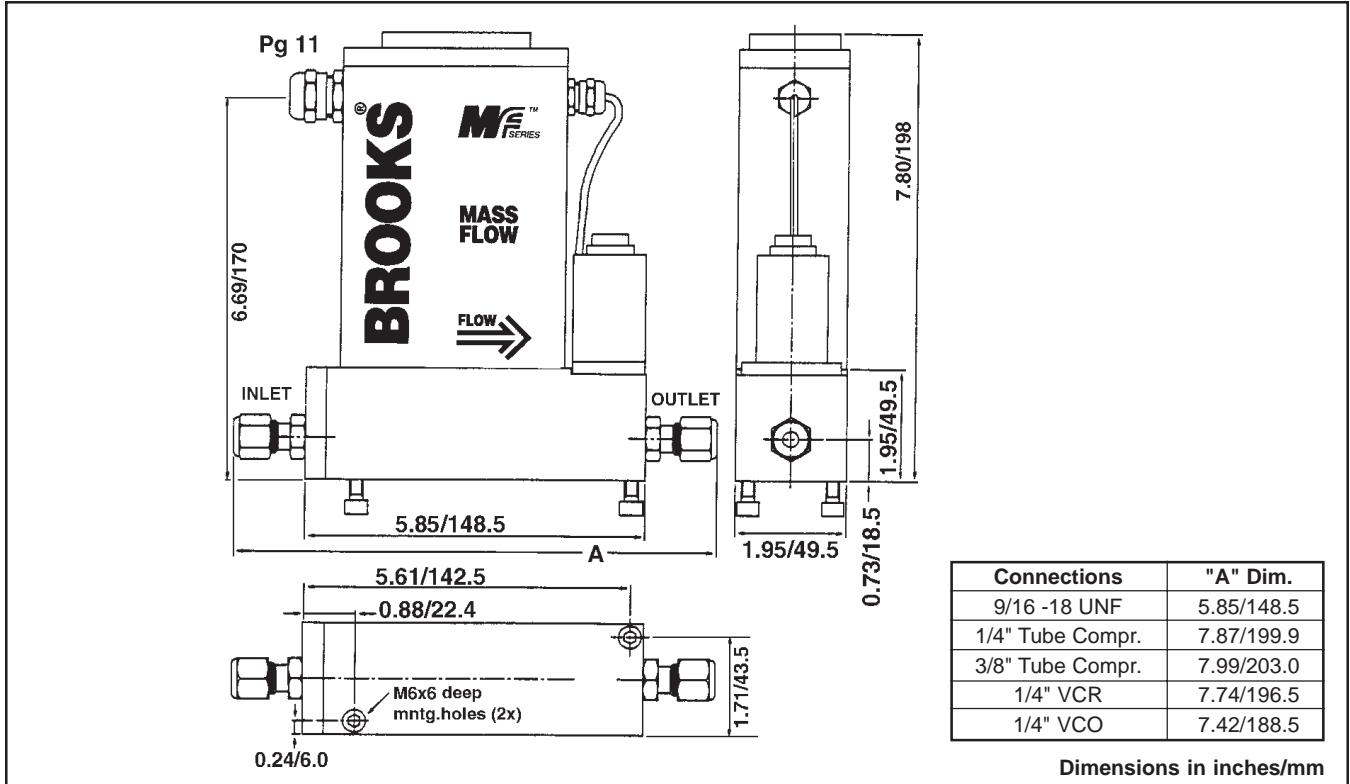

Figure 5 Model Mf51 Controller Dimensions

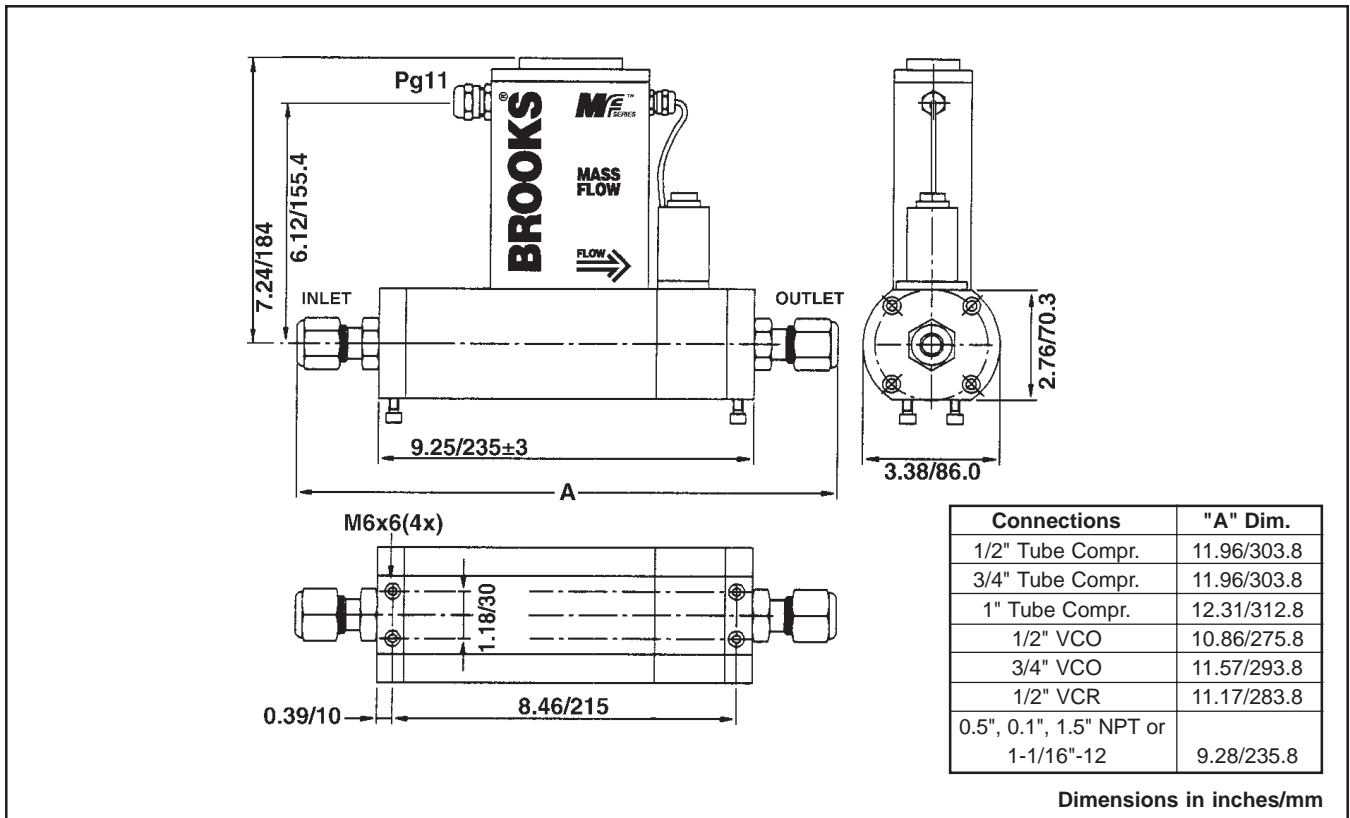

Figure 6 Model Mf53 Controller Dimensions

Brooks® Mf Series

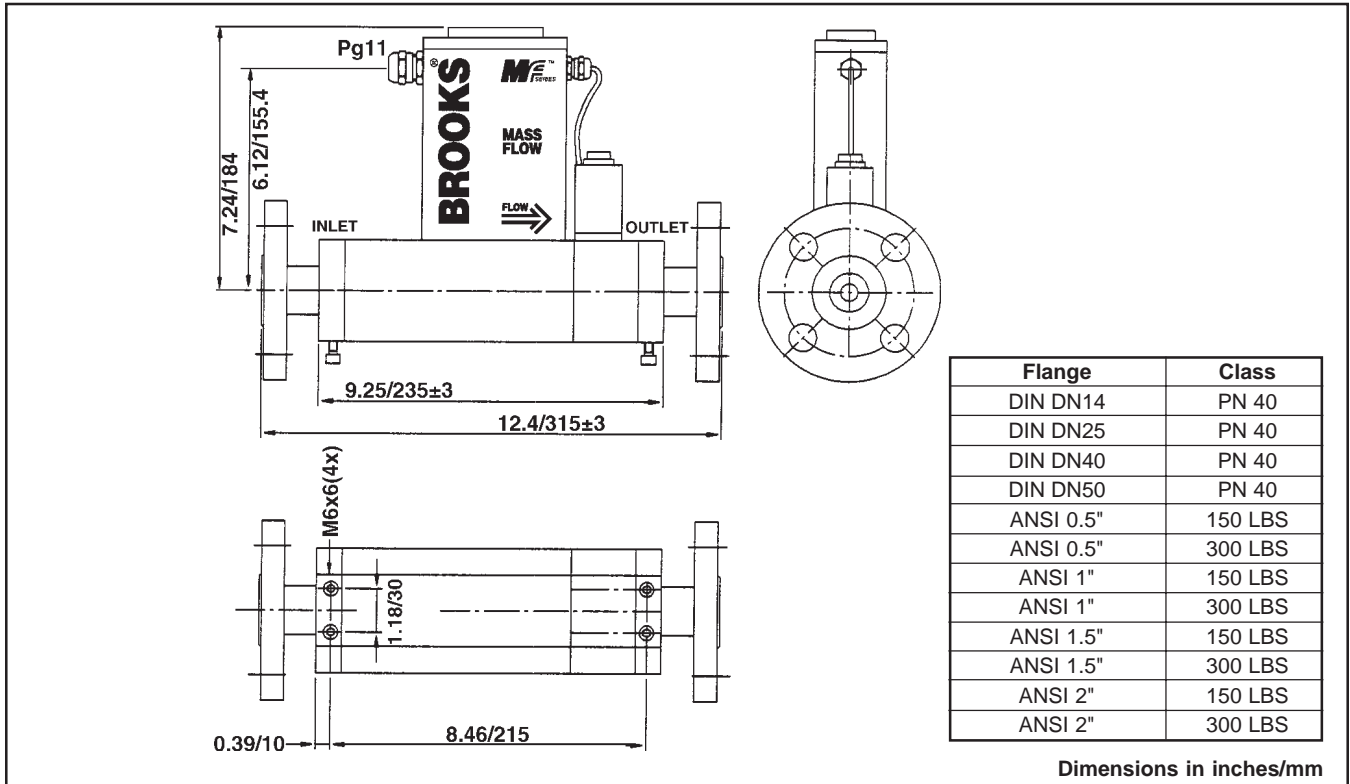

Figure 7 Model Mf53 Controller with Flange Dimensions

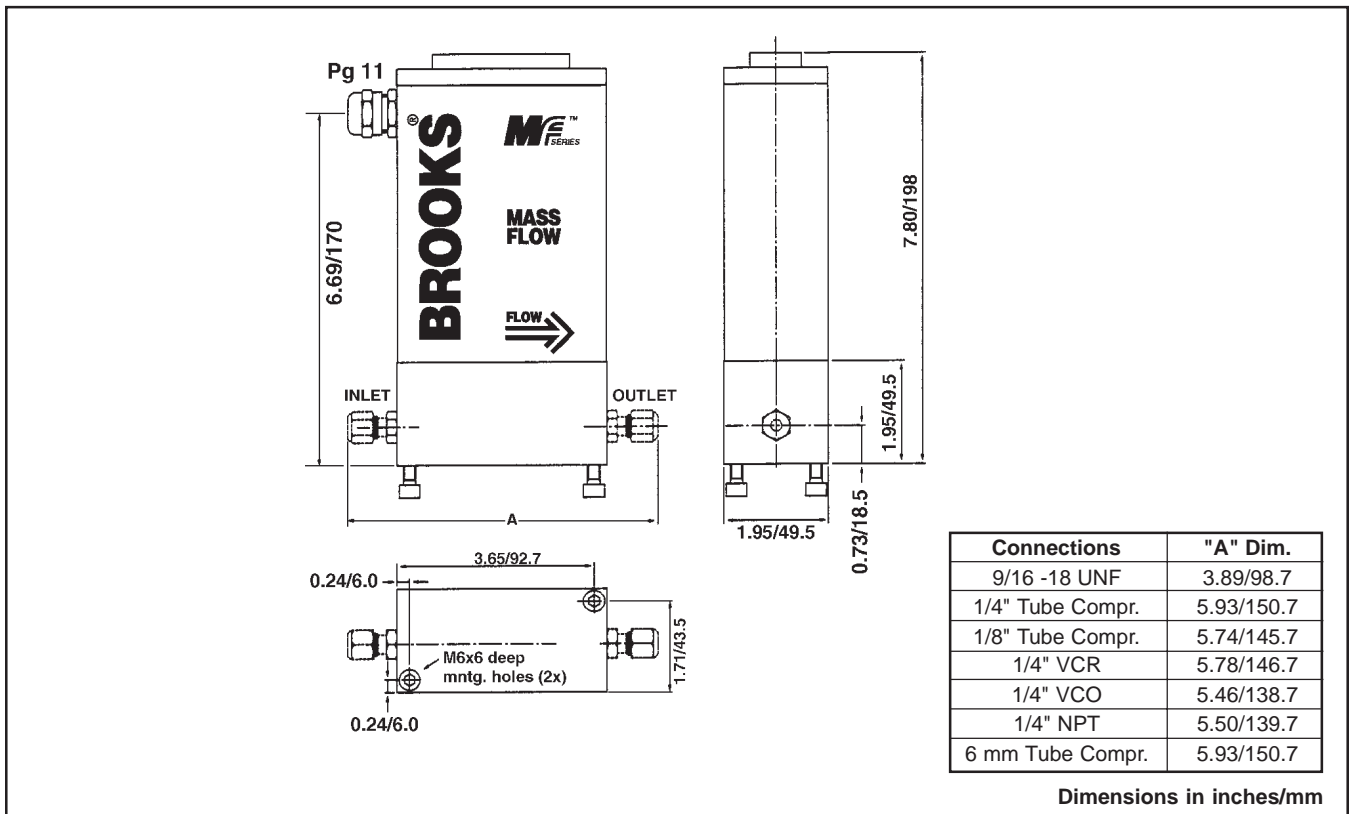

Figure 8 Model Mf60 Meter Dimensions

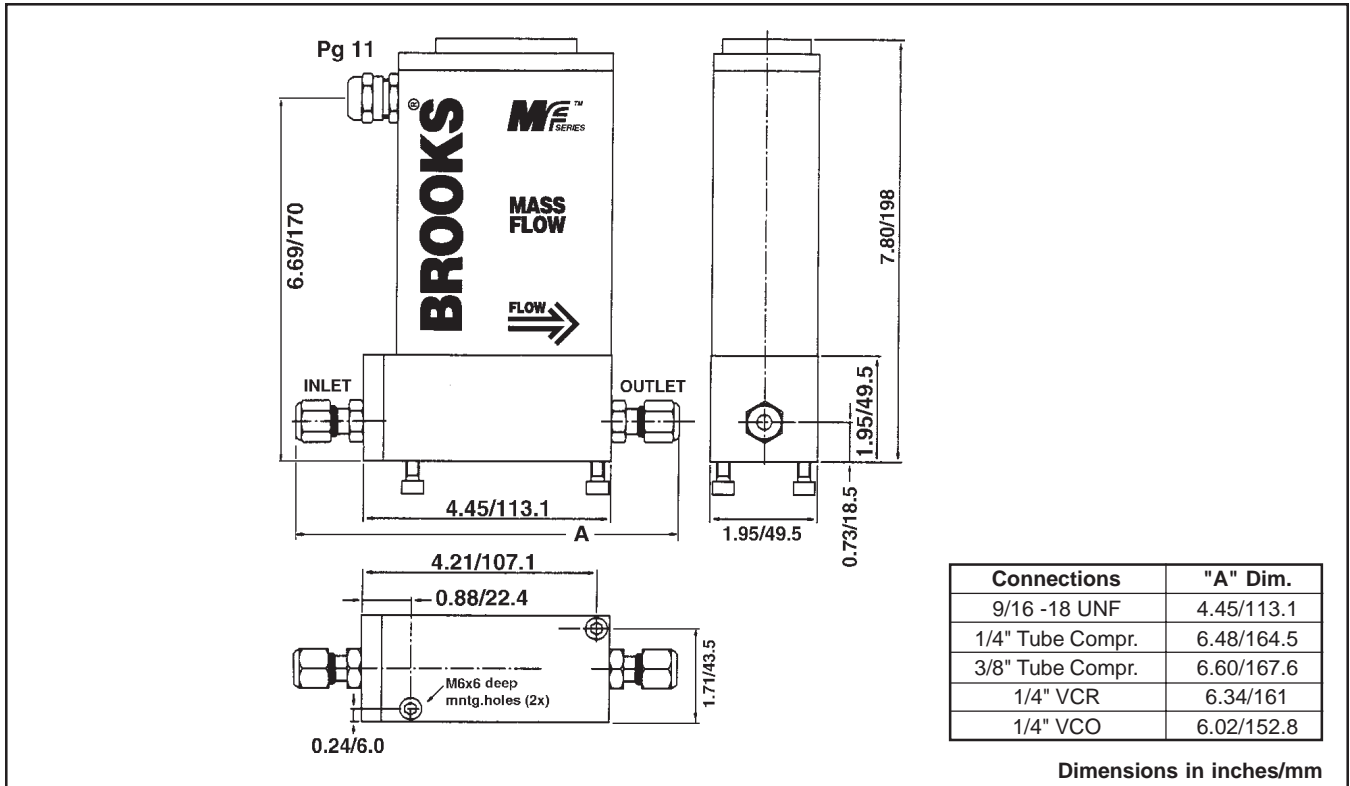

Figure 9 Model Mf61 Meter Dimensions

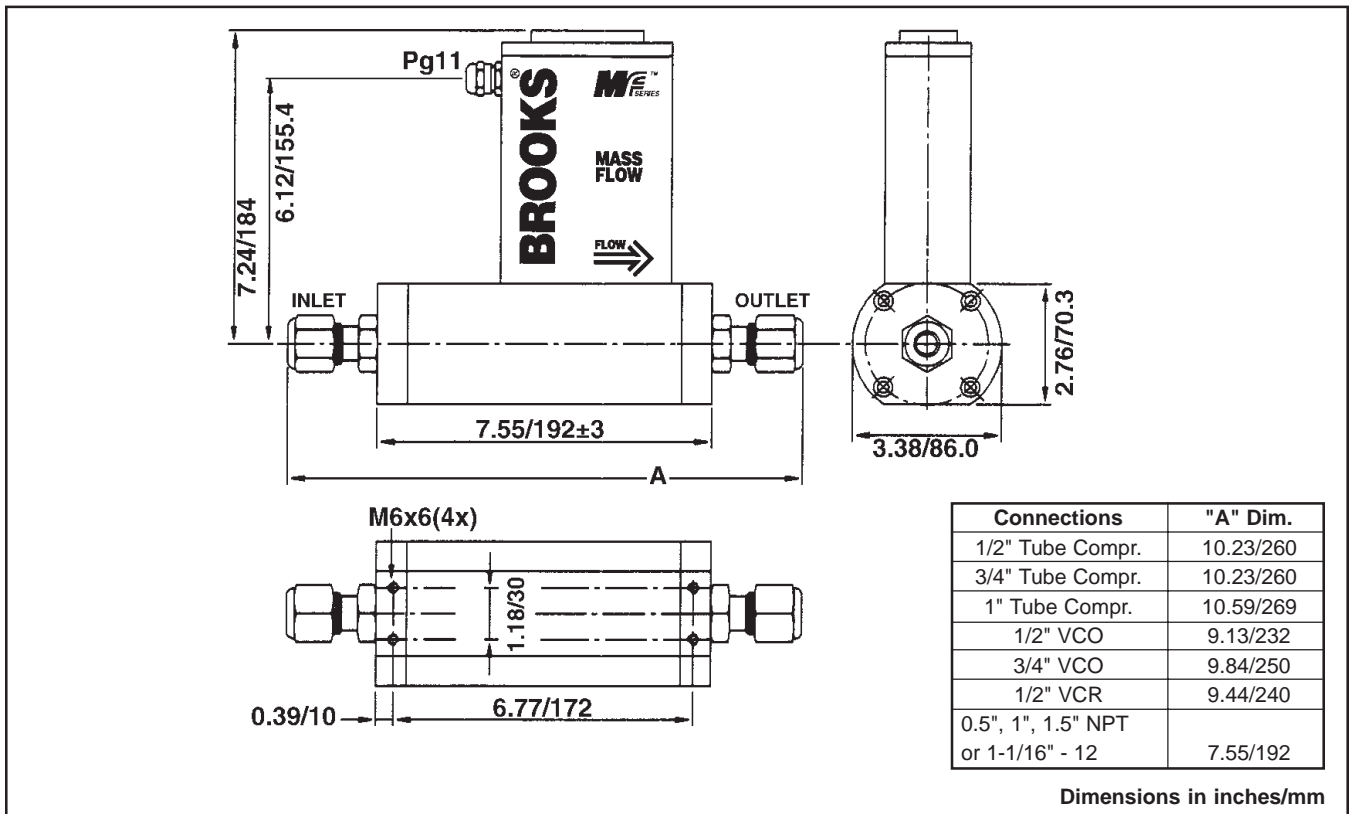

Figure 10 Model Mf63 Meter Dimensions

Brooks® Mf Series

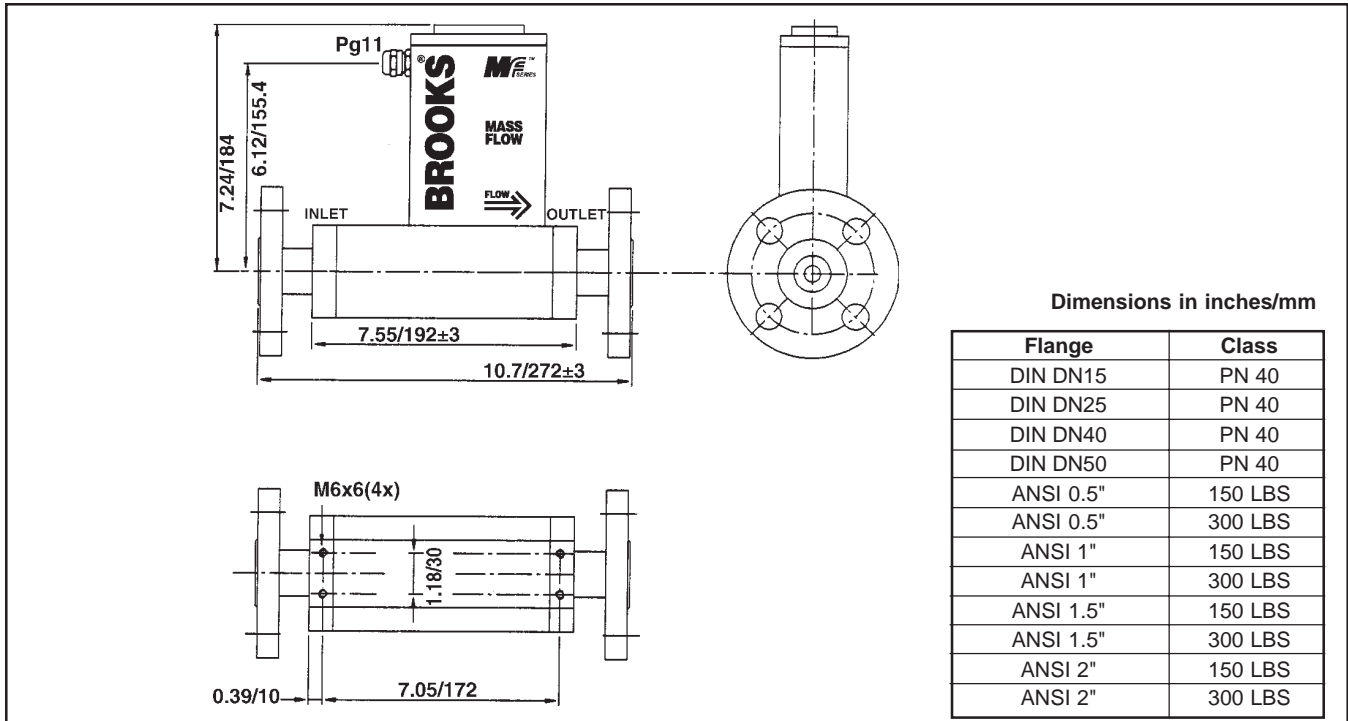

Figure 11 Model Mf63 Meter with Flange Dimensions

BROOKS LOCAL AND WORLDWIDE SUPPORT

- Brooks Instrument provides sales and service facilities around the world.
- Calibration facilities are available in locally based sales and service offices. Certified by our local Weights and Measures Authorities and traceable to the relevant international standards.

START-UP SERVICE AND IN-SITU CALIBRATION

- Brooks Instrument can provide start-up service prior to operation when required, if necessary under in-situ conditions, and the results will be traceable to the relevant international quality standards.

CUSTOMER SEMINARS AND TRAINING

- Brooks® can provide customer seminars and dedicated training to engineers, end users and maintenance persons.

HELP DESK

In case you need technical assistance:

- Americas ☎ 1-888-554-FLOW
- Europe ☎ +(31) 318 549 290 Within Netherlands ☎ 0318 549 290
- Asia ☎ +011-81-3-5633-7100

Due to Brooks Instrument's commitment to continuous improvement of our products, all specifications are subject to change without notice.

TRADEMARKS

- Brooks Brooks Instrument, LLC
- Kalrez DuPont Dow Elastomers
- Mf Brooks Instrument, LLC
- VCO Cajon Co.
- VCR Cajon Co.
- Viton DuPont Performance Elastomers



Brooks Instrument
407 West Vine Street
P.O. Box 903
Hatfield, PA 19440-0903 USA
T (215) 362-3700
F (215) 362-3745
E-Mail BrooksAm@EmersonProcess.com
www.BrooksInstrument.com

Brooks Instrument
Neonstraat 3
6718 WX Ede, Netherlands
T 31-318-549-300
F 31-318-549-309
E-Mail BrooksEu@EmersonProcess.com

Brooks Instrument
1-4-4 Kitasuna Koto-Ku
Tokyo, 136-0073 Japan
T 011-81-3-5633-7100
F 011-81-3-5633-7101
E-Mail BrooksAs@EmersonProcess.com

